CONVEX Digital Audio Tape Drive Service Guide



Order No. DHW-058

Second Edition
June 1992

CONVEX Press
Richardson, Texas
United States of America

**CONVEX
Digital Audio
Tape Drive
Service Guide**

Order No. DHW-058

Copyright © 1990, 1992 CONVEX Computer Corporation
All rights reserved.

This document is copyrighted. This document may not, in whole or part, be copied, duplicated, reproduced, translated, electronically stored, or reduced to machine readable form without prior written consent from CONVEX Computer Corporation.

Although the material contained herein has been carefully reviewed, CONVEX does not warrant it to be free of errors or omissions. CONVEX reserves the right to make corrections, updates, revisions, or changes to the information contained herein. CONVEX does not warrant the material described herein to be free of patent infringement.

UNLESS PROVIDED OTHERWISE IN WRITING WITH CONVEX COMPUTER CORPORATION (CONVEX), THE EQUIPMENT DESCRIBED HEREIN IS PROVIDED "AS IS" WITHOUT WARRANTY OF ANY KIND, EITHER EXPRESSED OR IMPLIED, INCLUDING, BUT NOT LIMITED TO, THE IMPLIED WARRANTIES OF MERCHANTABILITY AND FITNESS FOR A PARTICULAR PURPOSE. SOME STATES DO NOT ALLOW THE EXCLUSION OF IMPLIED WARRANTIES. THE ABOVE EXCLUSION MAY NOT BE APPLICABLE TO ALL PURCHASERS BECAUSE WARRANTY RIGHTS CAN VARY FROM STATE TO STATE. IN NO EVENT WILL CONVEX BE LIABLE TO ANYONE FOR SPECIAL, COLLATERAL, INCIDENTAL, OR CONSEQUENTIAL DAMAGES, INCLUDING ANY LOST PROFITS OR LOST SAVINGS, ARISING OUT OF THE USE OR INABILITY TO USE THIS EQUIPMENT. CONVEX WILL NOT BE LIABLE EVEN IF IT HAS BEEN NOTIFIED OF THE POSSIBILITY OF SUCH DAMAGE BY THE PURCHASER OR ANY THIRD PARTY.

CONVEX and the CONVEX logo ("C") are registered trademarks of CONVEX Computer Corporation.

CONVEX C100 Series and C200 Series are trademarks of CONVEX Computer Corporation.

ConvexOS is a trademark of CONVEX Computer Corporation.

C1, C120, C210, C220, C230, and C240 are trademarks of CONVEX Computer Corporation.

UNIX is a registered trademark of UNIX System Laboratories, Inc..

Archive and Python are trademarks of Archive Corporation.

Printed in the United States of America

Revision Information for

CONVEX Digital Audio Tape Drive Service Guide

Edition	Document No.	Description
Second	081-007130-001	<p data-bbox="588 577 831 609">Released June 1992.</p> <ul data-bbox="604 619 1478 850" style="list-style-type: none"><li data-bbox="604 619 1402 693">• Removed Appendix A, "Archive DAT Drive Configurator" and Appendix B, "Reporting Problems."<li data-bbox="604 703 1310 735">• Added information on the DAT AutoLoader tape drive.<li data-bbox="604 745 1478 787">• Added information on the manual-load tape drive with compression.<li data-bbox="604 798 1335 840">• Added information on the new horizontal-mount chassis.
First	081-007130-000	First release. December 1991.

FCC Notice

Note

This equipment generates, uses, and can radiate radio frequency energy. And, if not installed and used in strict accordance with the instruction manual, it may cause harmful interference to radio communications.

This equipment has been tested and found to comply with the limits for a Class A digital device, pursuant to Part 15 of the FCC Rules. These limits are designed to provide reasonable protection against harmful interference when the equipment is operated in a commercial environment.

When this equipment is operated in a residential area, it is likely to cause interference. In this case, the interference must be corrected at the operator's expense.

Do not connect external equipment to the utility outlets in CONVEX equipment cabinets. Unauthorized connection voids all agencies' emissions certification.

Contents

How to use this guide	xi
1 Description and specifications	1-1
1.1 Overview	1-1
1.2 DAT drive specifications	1-4
2 Unpacking and installing	2-1
2.1 Overview	2-1
2.2 Unpacking and inspection	2-1
2.2.1 Electrostatic discharge damage	2-1
2.2.2 Inspection for damage	2-2
2.2.3 Unpacking	2-2
2.2.4 Damage claims	2-2
2.3 Preinstallation	2-3
2.4 Installing a DAT chassis	2-7
2.5 Installing a power supply	2-10
2.6 Installing a DAT drive	2-12
2.6.1 Preinstallation	2-12
2.6.2 Vertical-mount tape drive chassis	2-15
2.6.3 Horizontal-mount tape drive chassis	2-17
2.6.4 Postinstallation	2-19
2.7 Postinstallation	2-19
2.8 Installing a cartridge magazine	2-20
3 Integration and test	3-1
3.1 Overview	3-1
3.2 Software integration	3-1
3.3 Testing the DAT drive	3-3
4 Maintenance procedures and IPB	4-1
4.1 Overview	4-1
4.2 Preventive maintenance	4-1
4.2.1 DAT drive front panel LEDs	4-1
4.2.2 Cleaning the DAT drive	4-4
4.2.3 Removing cassettes manually	4-4
4.3 Preservice procedures	4-5
4.4 Vertical-mount drive	4-10
4.4.1 Removal	4-11
4.4.2 Replacement	4-11
4.5 Horizontal-mount or AutoLoader tape drive	4-14
4.5.1 Removal	4-15
4.5.2 Replacement	4-15
4.6 DAT drive power supply	4-16
4.6.1 Removal	4-16
4.6.2 Replacement	4-16
4.7 DAT chassis cooling fan	4-18

4.7.1	Removal	4-19
4.7.2	Replacement	4-19
4.8	DAT chassis power breaker	4-19
4.8.1	Removal	4-19
4.8.2	Replacement	4-19
4.9	DAT chassis power switch	4-20
4.9.1	Removal	4-20
4.9.2	Replacement	4-20
4.10	DAT chassis temperature sensor	4-20
4.10.1	Removal	4-20
4.10.2	Replacement	4-20
4.11	Postservice procedures	4-21
4.12	DAT chassis and DAT drive IPB	4-21

Figures

Figure 1-1	DAT vertical-mount chassis (front view)	.1-2
Figure 1-1	Figure 1-2	.1-3
Figure 1-3	Vertical-mount subsystem block diagram	.1-3
Figure 1-4	Horizontal-mount subsystem block diagram	.1-4
Figure 2-1	Front panel power switch	.2-3
Figure 2-2	VMEbus chassis power switch	.2-4
Figure 2-3	EXP-105 power controller	.2-5
Figure 2-4	Expansion cabinet stabilizer bars	.2-6
Figure 2-5	External SCSI cable connection	.2-8
Figure 2-6	Front panel mounting bracket	.2-9
Figure 2-7	DAT drive power supply	2-11
Figure 2-8	Internal drive terminators	2-13
Figure 2-9	Vertical-mount drive position in DAT chassis	2-16
Figure 2-10	Horizontal drive installation in chassis	2-18
Figure 2-11	Cartridge magazine installation	2-21
Figure 3-1	Example /ioconfig file	.3-2
Figure 4-1	Manual-load DAT drive LED indicators	.4-2
Figure 4-2	AutoLoader drive LED indicators	.4-3
Figure 4-3	VMEbus chassis power control switch	.4-5
Figure 4-4	Expansion cabinet stabilizer bars	.4-7
Figure 4-5	Vertical-mount chassis rear panel	.4-8
Figure 4-6	Horizontal-mount chassis rear panel	.4-9
Figure 4-7	Vertical-mount DAT drive unit	4-10
Figure 4-8	DAT drive terminators	4-12
Figure 4-9	Horizontal-mount DAT drive unit	4-14
Figure 4-10	DAT drive power supply	4-17
Figure 4-11	DAT chassis fan and power control FRUs	4-18
Table 4-3	Horizontal-mount drive parts list	4-22
Figure 4-12	DAT vertical-mount drive and power supply IPB	4-23
Figure 4-13	DAT horizontal-mount drive IPB	4-24
Figure 4-14	Fan, sensor, breaker, and switch IPB	4-26
Figure 4-15	DAT vertical-mount drive and power cabling IPB	4-28
Figure 4-16	DAT horizontal-mount drive and power cabling IPB	4-29
Figure 4-17	DAT horizontal-mount internal SCSI cabling IPB	4-30

Tables

Table 1-1	Single DAT drive specifications1-4
Table 1-2	DAT chassis specification (four drives)1-5
Table 2-1	Static charge levels and relative humidity2-1
Table 2-2	Dip switch settings with SCSI address	2-14
Table 4-1	DAT drive LED indicators	4-3
Table 4-2	Vertical-mount tape drive and power supply parts list	4-22
Table 4-4	Fan, sensor, breaker, and switch list	4-25
Table 4-5	DAT drive and power cabling list	4-27
Table 4-6	Miscellaneous mechanical parts list	4-31

How to use this guide

Purpose and audience

The *CONVEX Digital Audio Tape Service Guide* provides a general overview of the digital audio tape (DAT) drive and related hardware and how to:

- Install the DAT drive, DAT chassis, and related hardware
- Integrate the DAT drive into the CONVEX operating system (ConvexOS)
- Test the DAT drive and related hardware
- Perform preventive maintenance on the DAT drive
- Remove and replace the DAT drive and related hardware

This document is intended for:

- CONVEX customer support engineers and CONVEX manufacturing personnel
- CONVEX customers who need to install and maintain their own DAT drive subsystem and related hardware

Scope

The information presented in this service guide applies exclusively to the DAT drive subsystem and related hardware. The DAT drive subsystem can be used with all CONVEX computers that have a VMEbus chassis with a SCSI host adapter installed and have ConvexOS V8.1 or later installed.

Organization

This document consists of the following sections:

- **Chapter 1, "Description and specifications"**—Describes the DAT drive, DAT drive subsystem, and related hardware at the block-diagram level. Defines and lists the electromechanical and environmental specifications.
- **Chapter 2, "Unpacking and installation"**—Provides guidelines on how to unpack and install the DAT drives and related hardware.
- **Chapter 3, "Integration and test"**—Explains how to integrate the DAT drive subsystem into the ConvexOS operating system. Explains how to test the DAT drive subsystem and related hardware.
- **Chapter 4, "Maintenance procedures and IPB"**—Provides removal and replacement instructions for the DAT drives and related hardware.

Notational conventions

Notational conventions are systems of characters, symbols, terms, or abbreviated expressions used to express technical facts or quantities as established by this guide. The following notational conventions are used in this document:

- **Boldface** indicates user-entered information for a computer program and should be entered exactly as they appear.
- *Italic* is used for emphasis and also designates file names, program names, directory paths, release tape titles, and titles of publications.
- All CONVEX illustrations have an illustration file number at the bottom right-hand corner that is for CONVEX use only.

The following are examples of warnings, cautions, and notes and their typical content as used in CONVEX documents:

Warning

Warnings highlight procedures or information necessary to avoid injury to personnel. A warning immediately precedes the critical information and includes a description of the hazard.

Caution

Cautions highlight procedures or information necessary to avoid damage to equipment, damage to software, loss of data, or invalid test results. A caution immediately precedes the critical information and includes a description of the possible damage.

Note

Notes highlight information that is supplemental in nature. The note immediately precedes or follows the highlighted information.

Associated documents

Using this hardware successfully may require more information than is contained in this manual.

The following documents will help you with the DAT drive and related hardware:

- *CONVEX System Management Doc Set*, Order No. DSW-015, consists of *Managing ConvexOS: Operations Guide* and *Managing ConvexOS: Configuration Guide*
- *CONVEX SCSI Host Adapter Service Guide*, Order No. DHW-060
- *CONVEX DAT/3480 Tape Subsystem Diagnostics Manual*, Order No. DHW-247
- *Archive Python DDS DAT Tape Drive Product Description Manual* (CONVEX part number 900-000601-001)
- *Archive Python DDS-DC Data Compression DAT Tape Drive Product Description Manual* (CONVEX part number 900-000626-001)
- *Archive Python AutoLoader DAT Tape Drive Product Description Manual* (CONVEX part number 900-000627-001)

Ordering documents

To order the current edition of this or any other CONVEX document, send requests to:

CONVEX Computer Corporation
Customer Service
PO Box 833851
Richardson TX 75083-3851 USA

Include the order number with the request. The order number is on the title page of the manual and begins with the letters "DSW" or "DHW."

Technical assistance

Hardware, software, and documentation support can be obtained through the CONVEX Technical Assistance Center (TAC):

- From locations in the continental United States:
 - Customers call (800)952-0379
 - CONVEX employees call (800)545-4839
- From locations in Canada, call (800)345-2384.
- From all other locations, contact the nearest CONVEX office.

Using the contact utility

The TAC recommends using the `contact` utility to report a hardware, software, or documentation problem. The `contact` utility is an interactive program that helps the TAC track reports and route them to the CONVEX personnel most qualified to fix a problem. After you invoke `contact`, it prompts you for information about the problem. When you finish your report, `contact` mails it to the TAC electronically.

The TAC notifies you within 48 hours that your report has been received. Using `contact` requires:

- UNIX-to-UNIX Communications Protocol (UUCP) connection to the TAC
- Full path name of the program or utility in question
- Version number of the program or utility in question

Refer to the `contact(1)` man page for complete details.

1.1 Overview

The CONVEX digital audio tape (DAT) drive system is a high-capacity tape back-up system using a 3 inch by 2 inch by 0.5 inch DAT cassette with a 4-mm tape width. There are two tape drives in the CONVEX DAT drive system: a manual-load single-cassette drive and an AutoLoader (stacker) drive that accommodates a 5-cartridge magazine.

The manual-load DAT drive has the following features:

- A maximum of 1.3 Gbytes of storage on a 60-meter DAT cassette or 1.9 Gbytes on a 90-meter DAT cassette
- Sustained data transfer rate of 183 kbytes/s
- Recording density of 61,000 bits per inch
- Areal density of 114 Mbytes per square inch
- ANSI digital data storage (DDS) recording format
- Helical scan recording
- Average access time of less than 20 seconds for a 60-meter DAT cassette or less than 30 seconds for a 90-meter DAT cassette

The AutoLoader is mounted in the DAT chassis and has the following features:

- With the 5-cartridge magazine, a maximum of 6.5 Gbytes of storage on a 60-meter DAT cassette or 10 Gbytes on a 90-meter DAT cassette
- Transfer rate of 183 kbytes/s
- ANSI digital data storage (DDS) recording format
- Magazine indexing of less than 10 seconds for a load/unload cycle

Data compression (DDS-DC) is standard on the AutoLoader drive and may be enabled through software. It is also standard on the manual-load drive with CONVEX part number 207-000021-200. Drives with compression can be used to read and write standard uncompressed data. Compression provides the following:

- Typical storage capacity of 2.6 Gbytes on a 60-meter cassette and 4.0 Gbytes on a 90-meter cassette, double that of noncompressed storage (actual storage capacity is data-dependent)
- Sustained data transfer rate of up to 366 kbytes/s (actual transfer rate is dependent upon the compression ratio)

Refer to one of the following for more information on the individual drive:

- *Archive Python DDS DAT Tape Drive Product Description Manual* for the manual-load drive without compression
- *Archive Python DDS-DC Data Compression DAT Tape Drive Product Description Manual* for the manual-load drive with compression
- *Archive Python 4590T and 4592NP AutoLoader Product Description Manual* for the AutoLoader drive

Refer to the *ConvexOS Tape System User's Guide* for information on selecting data compression.

The vertical-mount chassis shown in Figure 1-1 is no longer manufactured but is shown here for information purposes. It has been replaced by a horizontal-mount chassis, shown in Figure 1-2. See Chapter 2 for details on installing and configuring the chassis.

Figure 1-1
DAT vertical-mount chassis (front view)

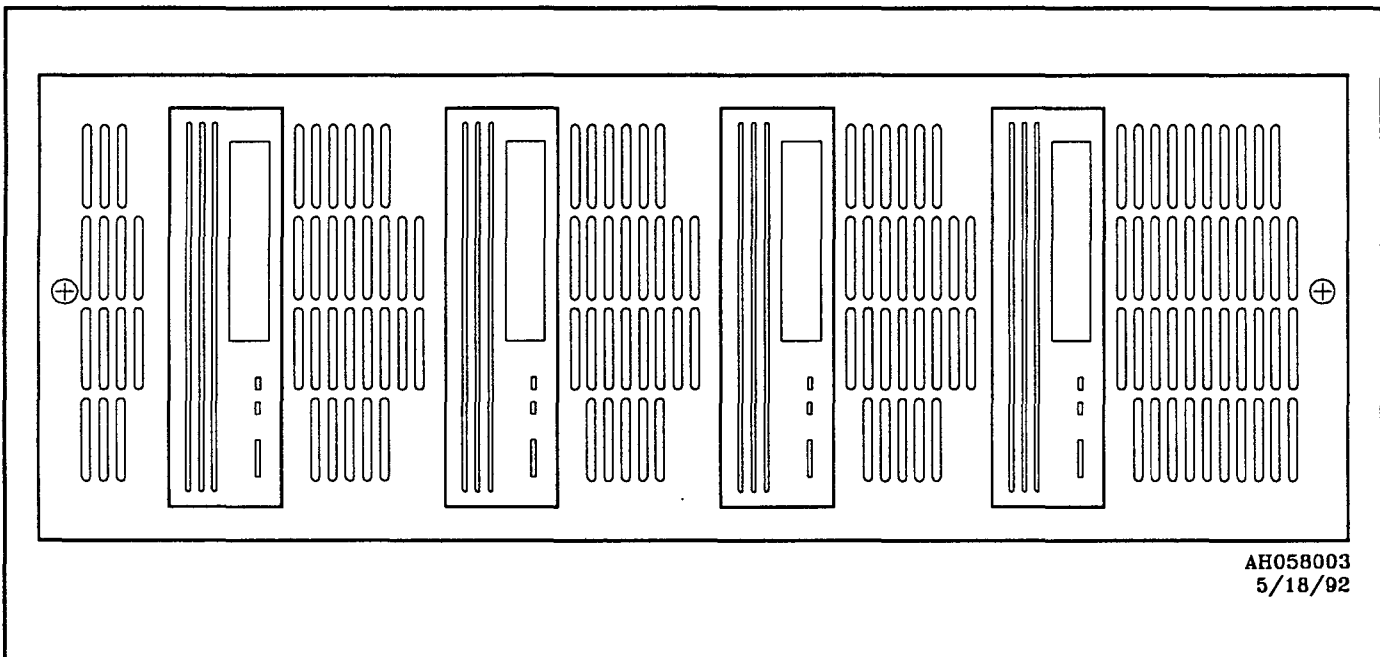
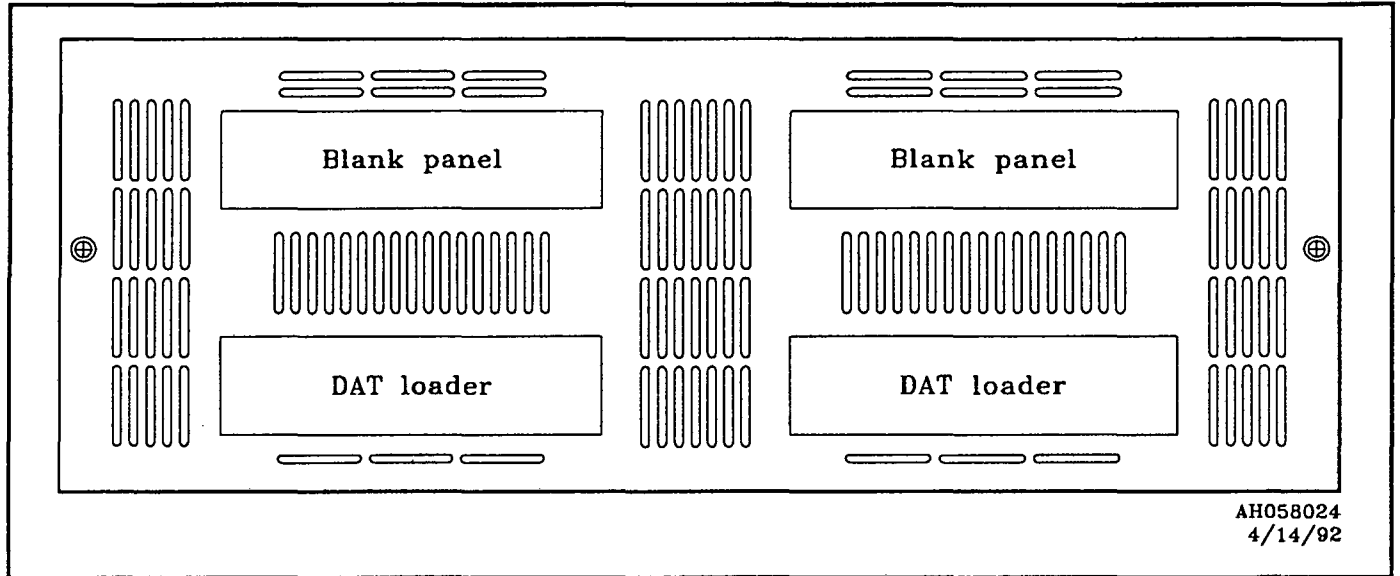

Figure 1-2
DAT horizontal-mount chassis (front view)



A small computer systems interface (SCSI) host adapter installed in a VMEbus chassis is connected with a single cable to the DAT chassis. An internal daisy-chain cable connects one to four DAT drives together within a DAT chassis to form a DAT subsystem. A maximum of 4 drives can be supported by one host adapter. Figure 1-3 shows a block diagram for the vertical-mount chassis, and Figure 1-4 shows one for the horizontal-mount chassis.

Figure 1-3
Vertical-mount subsystem
block diagram

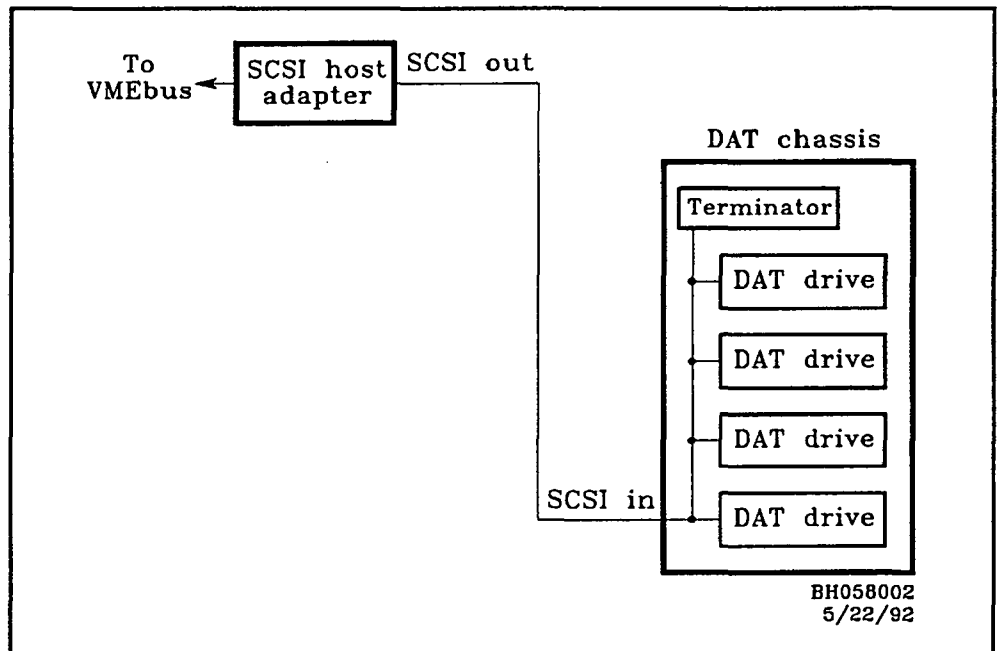
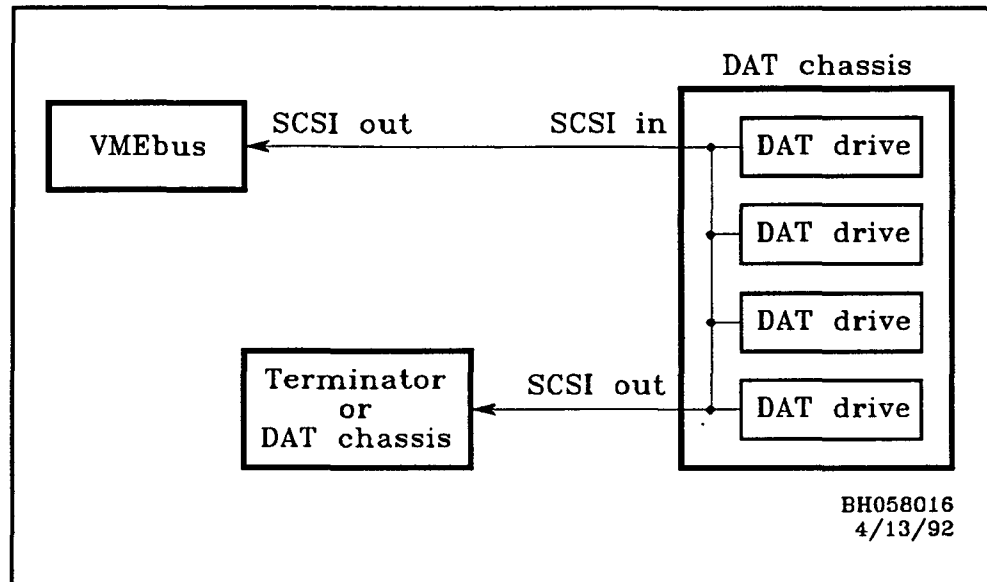

Figure 1-4
Horizontal-mount
subsystem block diagram



1.2 DAT drive specifications

Table 1-1 and Table 1-2 list operational specifications for the DAT drive system.

Table 1-1
Single DAT drive
specifications

Parameter	Single drive	AutoLoader (drive plus Loader)
Width	5.7 in. (146 mm)	5.7 in. (146 mm)
Height	1.6 in. (41 mm)	3.0 in. (77 mm)
Depth	8.0 in. (203 mm)	11.6 in. (294 mm)
Weight	2.5 lbs (1.2 kg)	3.14 lbs (1.43 kg)
Voltage range Domestic International	0.3 amps @ 120 Vac ±10% 0.2 amps @ 240 Vac ±10%	Same as single drive
Temperature range Operating Nonoperating	+41° F to +113° F (+5° C to +45° C) -104° F to +149° F (-40° C to +65° C)	Same as single drive
Temperature change	≤ 3.6° F/min (2.0° C/min)	Same as single drive
Humidity range Operating Nonoperating	20% to 80% noncondensing 0% to 90% noncondensing	Same as single drive

Table 1-2
DAT chassis specification
(four drives)

Parameter	Value/comment
Width	19.0 in. (48.26 cm)
Height	7.0 in. (17.78 cm)
Depth	17.5 in. (44.45 cm)
Weight	Chassis with 1 drive 19.5 lbs (8.85 kg) Add 5.5 lbs (2.49 kg) for each add-on drive with power supply
Maximum current usage	
Domestic	1.25 amps @ 90 Vac in chassis with 4 drives
International	1.25 amps @ 90 Vac in chassis with 4 drives
Voltage range	100-240 in chassis with 4 drives
Temperature range	
Operating	+41° F to +113° F (+5° C to +45° C)
Nonoperating	-104° F to +149° F (-40° C to +65° C)
Temperature change	≤ 3.6° F/min (2.0° C/min)
Humidity range	
Operating	20% to 80% noncondensing
Nonoperating	0% to 90% noncondensing
Wet bulb	79° F (26° C)
Altitude (operating)	-300 ft to +15,000 ft (-100 m to +4,575 m)

2.1 Overview

This chapter discusses unpacking and inspection, identifies major components of the DAT system assembly, and provides installation procedures.

2.2 Unpacking and inspection

This section gives general guidelines for unpacking and inspecting the DAT drives and related hardware. Also, this section gives safety and equipment damage precaution information.

2.2.1 Electrostatic discharge damage

Typically, electrostatic discharge (ESD) damage occurs to electronic circuit boards during handling. Static charges take place when various objects are separated or rubbed together, often creating a high-voltage charge. If a high-voltage charge is discharged into electronic computer circuits, the charge damages the electronic components. The main factors that determine a voltage level charge are:

- Types of materials
- Relative humidity
- Rate of change or separation

Table 2-1 lists an approximation of ESD levels based on various personnel activities and humidity levels.

Table 2-1
Static charge levels and relative humidity

Personnel activity ¹	Humidity ² & charge levels (volts ³)			
	26%	32%	40%	50%
Person walking across linoleum floor	6,150 V	5,750 V	4,625 V	3,700 V
Person walking across carpet	18,450 V	17,250 V	13,875 V	11,100 V
Person getting up from a plastic chair	24,600 V	23,000 V	18,500 V	14,800 V

¹Source: B. A. Unger, *Electrostatic Discharge Failures of Semiconductor Devices* (Bell Laboratories, 1981).

²A high rate of air flow produces higher static charges than a low air-flow rate, for the same relative humidity level.

³Some data in this table has been extrapolated.

2.2.2 Inspection for damage

All shipping containers have been specially designed to protect their contents under normal shipping conditions. Carefully inspect each carton for signs of shipping damages as it is unpacked. If damage is found after visual inspection, document the damage with photographs and contact the transport carrier immediately.

2.2.3 Unpacking

The customer's bill of material lists all equipment shipped from CONVEX. It should be used as a checklist to ensure that all equipment has arrived.

The procedure for unpacking the shipping container is:

1. Unpack each item of equipment from its shipping container.
2. Inspect each item of equipment for any sign of shipping damage as it is unpacked.
3. If equipment damage is found, document and proceed to the next section.

Note

Save all packing material until after operational checkout of the equipment. This enables equipment to be returned safely to CONVEX, if required.

2.2.4 Damage claims

If the DAT drives or related hardware is damaged, a damage claim must be completed. Damage claims should be completed by the customer and given to the shipping representative. Claim forms are normally obtained from the shipping representative.

2.3 Preinstallation

This section gives steps to be done before installing the DAT system into an existing expansion cabinet or a DAT drive into an existing DAT chassis.

Caution

Shut down the system before removing power to the existing expansion cabinet. Failure to do so will cause a system crash and possible loss of data. Refer to *Managing ConvexOS: Operations Guide* for the shutdown procedures for a CONVEX supercomputer.

Note

The maximum length for the SCSI host adapter cable to the DAT chassis is approximately 50 ft (16 m).

The maximum length for the SCSI cable, including cable internal to the chassis, is approximately 75 ft (25 m).

1. Turn the processor's front panel keyswitch to the OFF position. See Figure 2-1.

Figure 2-1
Front panel power switch

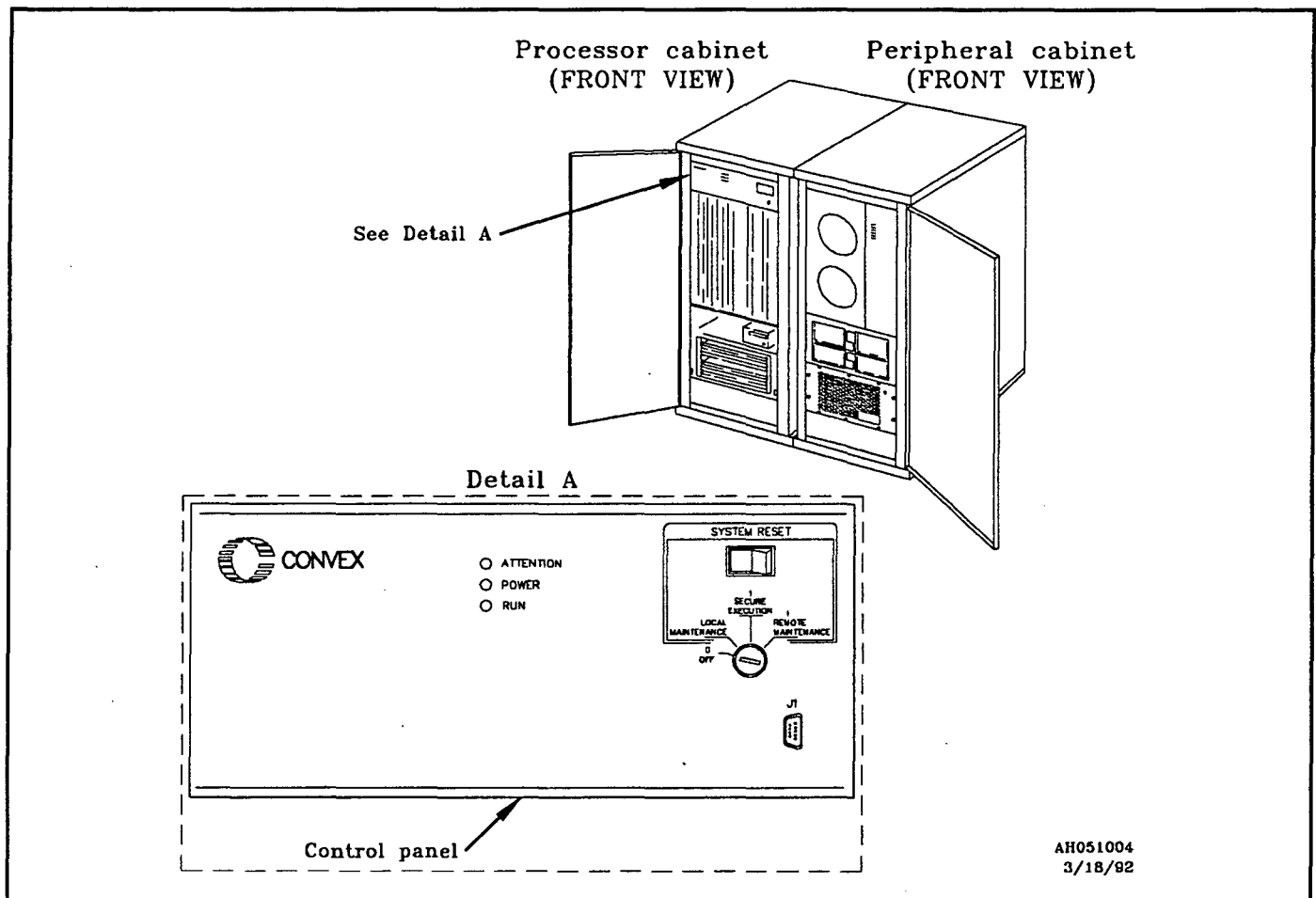

Caution

Remove power to the VMEbus chassis before installing or removing equipment. Failure to do so will damage electronic equipment components.

2. Set the VMEbus chassis power control switch to the OFF position. See Figure 2-2.

Figure 2-2
VMEbus chassis power switch

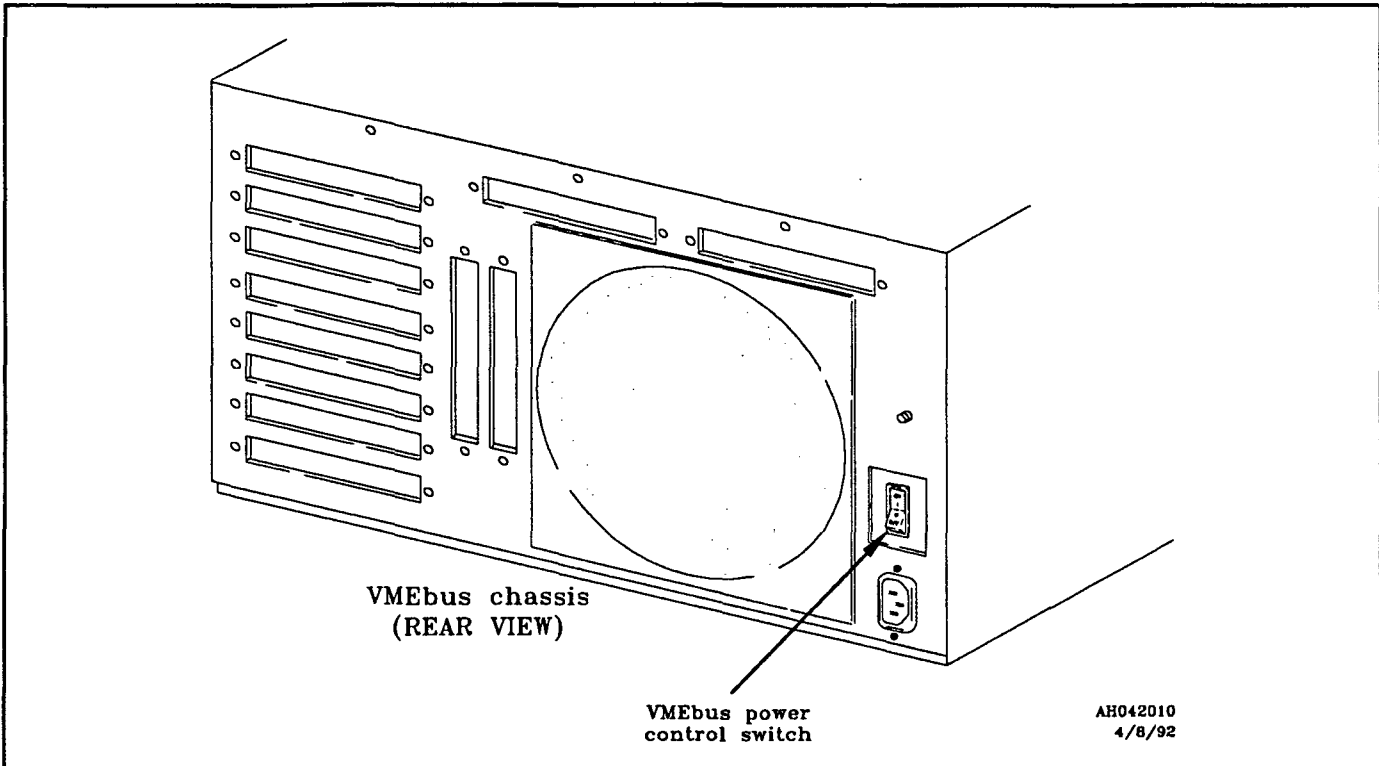

Caution

Remove power to the expansion cabinet before installing or removing equipment. Failure to do so will damage electronic equipment components.

3. Remove power to the expansion cabinet.
 - To remove power from a CONVEX EXP-101 or EXP-102 expansion cabinet, disconnect the cabinet's power cord.
 - To remove power from a CONVEX EXP-105 high-performance expansion cabinet, set the main power control switch to the OFF position. See Figure 2-3.

Figure 2-3
EXP-105 power controller

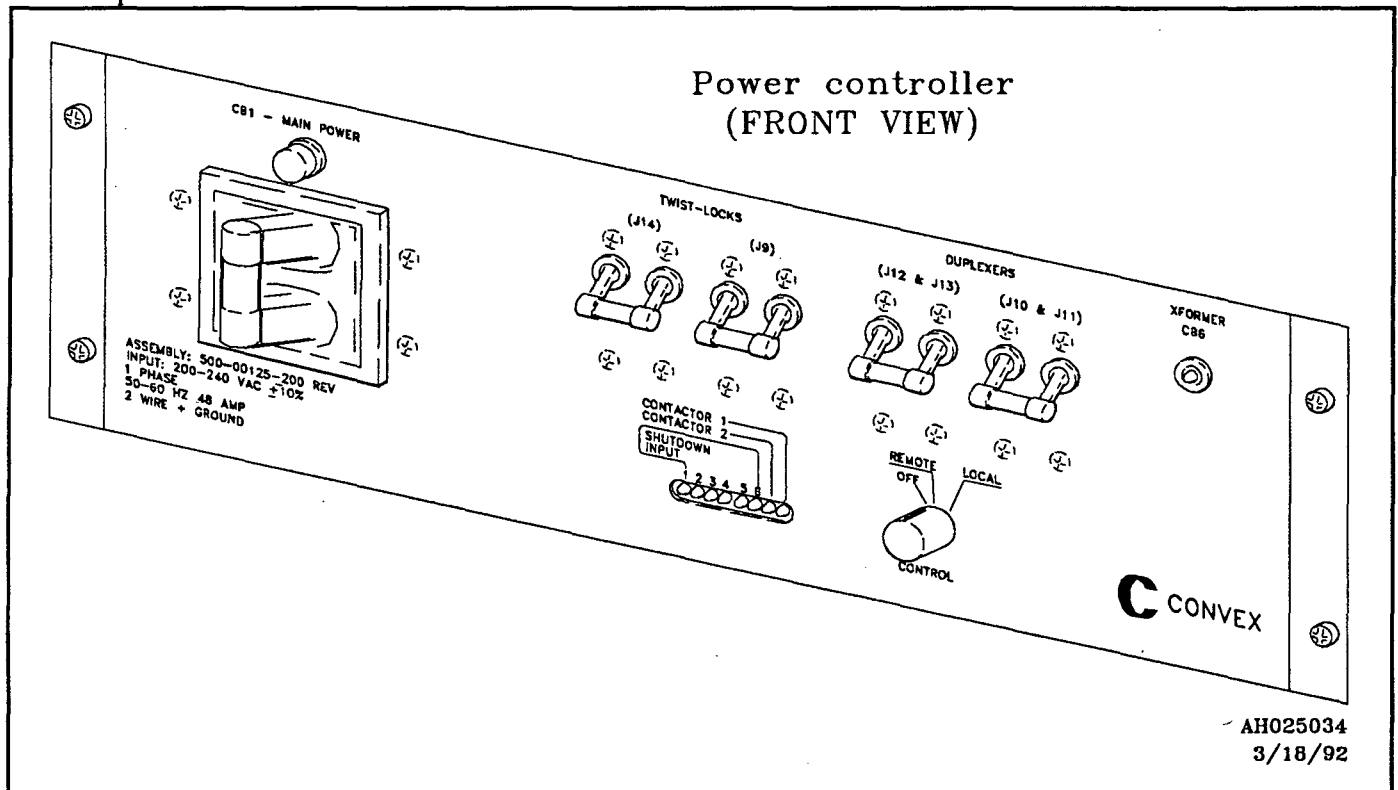

Warning

Expansion cabinet stabilizer bars *must* be extended before installing a DAT chassis or before extending the DAT chassis assembly from its expansion cabinet for service. Failure to do so will make the expansion cabinet unstable, increase the possibility of it falling forward, can cause injury to personnel, and will cause damage to equipment.

4. Extend the expansion cabinet stabilizer bars and adjust the feet until they are in firm contact with the floor. See Figure 2-4.

Figure 2-4
Expansion cabinet stabilizer bars

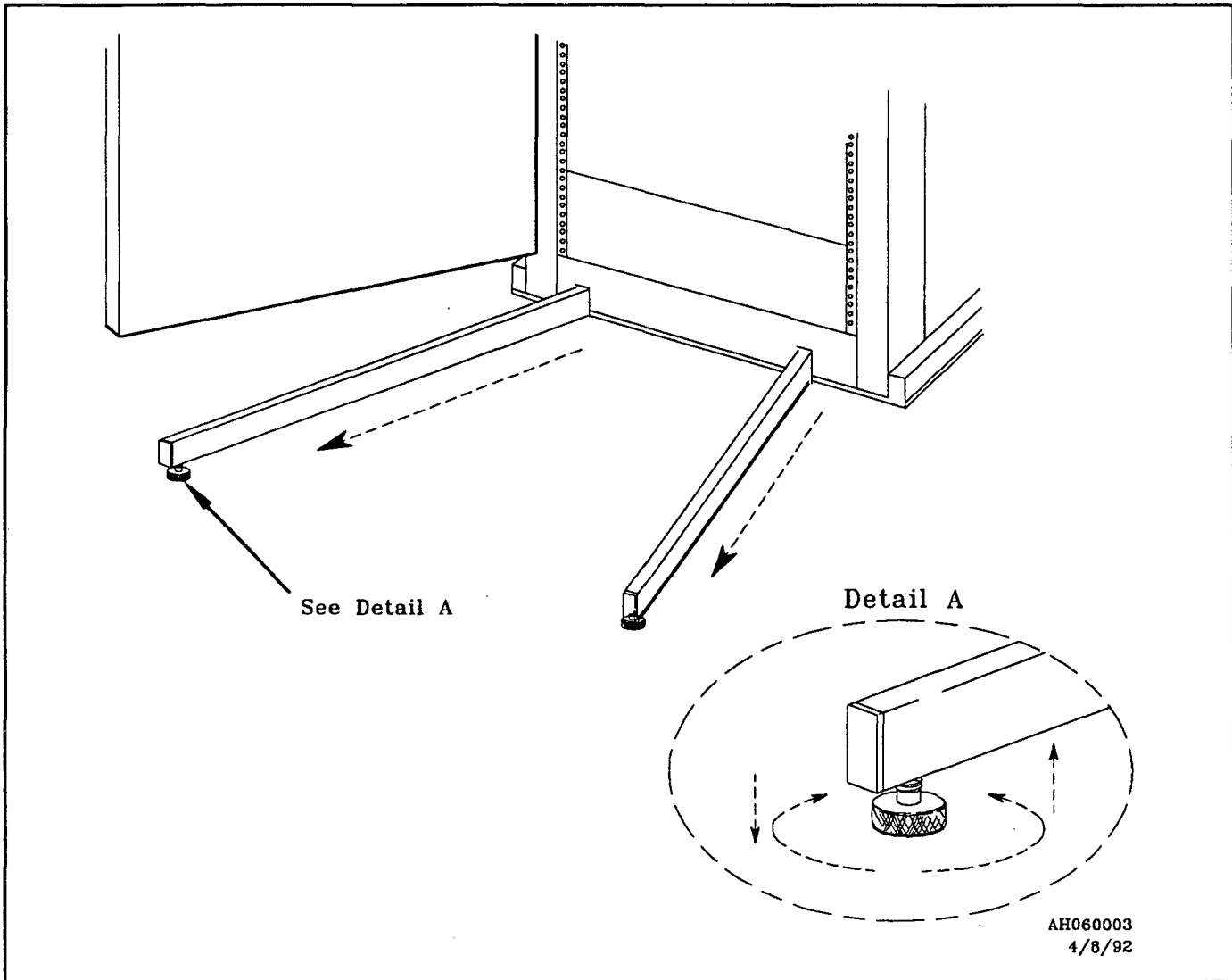

5. Install the SCSI host adapter in the VMEbus chassis. Refer to the *CONVEX SCSI Host Adapter Service Guide* for more information on installing the SCSI host adapter.

2.4 Installing a DAT chassis

This section gives the procedure for installing a DAT chassis into an expansion cabinet.

Notes

The total cable length allowed between the SCSI host adapter and the SCSI bus terminator is approximately 75 ft (24 m).

The CONVEX DAT system can be installed in any CONVEX expansion cabinet. The recommended position for the DAT chassis is in the upper third of the expansion cabinet.

1. Select a position 7.0 inches in height in the expansion cabinet and remove the blank panels to open the space for the chassis installation.
2. Install the left and right chassis rails in the selected position in the expansion cabinet making sure the rails are level front to back and level side to side.
3. Carefully place the DAT chassis in the rails and slide into the expansion cabinet.
4. Install the 2 screws that hold the DAT chassis to the front RETMA rails in the expansion cabinet.
5. Connect the input cable from the SCSI host adapter to the connector on the rear of the DAT chassis. See Figure 2-5.
6. Connect the power cable to the rear of the DAT chassis. See Figure 2-5.

Figure 2-5
External SCSI cable connection

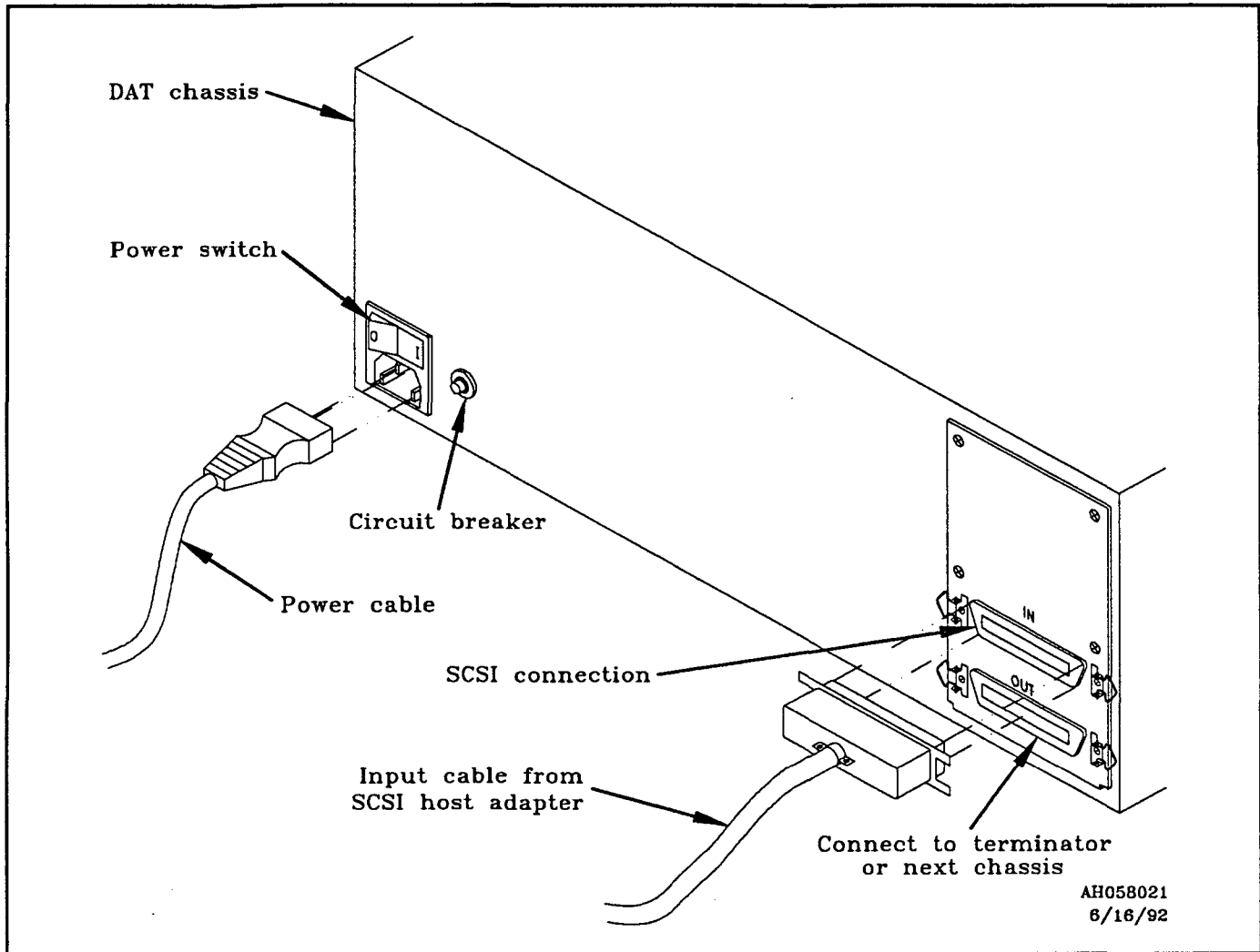

Caution

Ensure that the grounding pads are firmly attached to the front panel mounting brackets. Failure to do so may cause ESD damage to components within the DAT chassis.

7. Attach the mesh pieces, 2 per bracket, to the front panel mounting brackets. See Figure 2-6.

Figure 2-6
Front panel mounting bracket

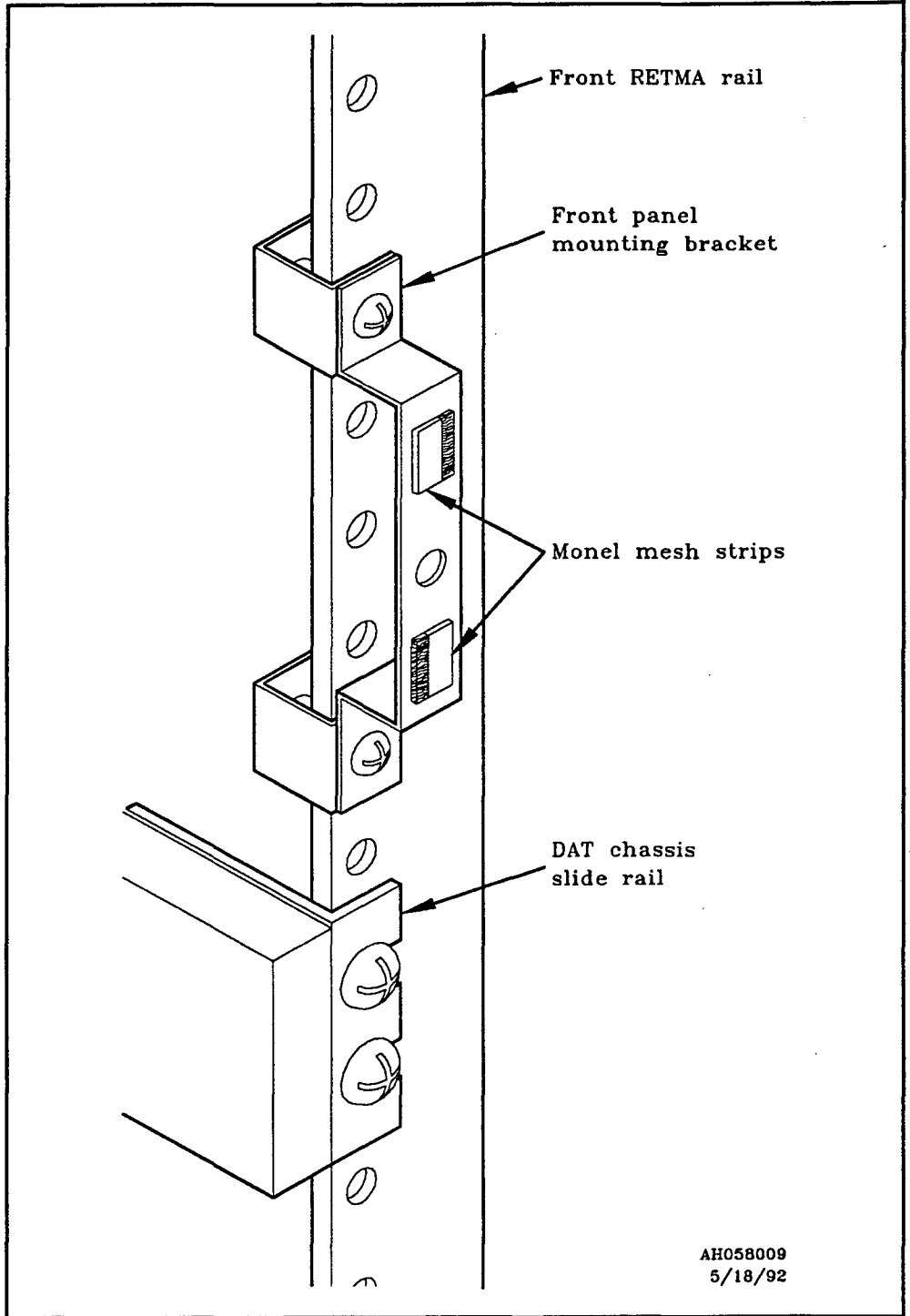

8. Install the 2 front panel mounting brackets on the first 4 holes in the front RETMA rail above the DAT chassis with the screws provided.
9. Set the DAT chassis power switch to the ON position.
10. Position the front panel on the DAT chassis and secure the 2 captive screws.
11. To daisy-chain chassis together, cable the SCSI OUT connector on the rear of the first chassis to the SCSI IN connector on the back of the second chassis. Install a terminator to the SCSI OUT connector of the last chassis.
12. Do the postinstallation steps listed in Section 2.7 on page 2-19.

2.5 Installing a power supply

This section describes how to install a power supply into an existing DAT chassis.

1. Do the preinstallation steps listed in Section 2.3 on page -.
2. Set the DAT chassis power switch to the OFF position. See Figure 2-5.
3. Disconnect the SCSI input cable and the power cable from the rear of the DAT chassis. See Figure 2-5.
4. Unlock the 2 captive screws holding the front panel of the DAT chassis and remove the panel.
5. Remove the 2 screws holding the DAT chassis to the front RETMA rails of the expansion cabinet.
6. Pull the DAT chassis out of the expansion cabinet until the side rails lock into place.
7. Remove the 14 captive screws that secure the top of the DAT chassis and remove the panel.
8. Install the 4 screws (A in Figure 2-7) that attach the power supply to the power supply bracket.
9. Remove the tape drive power cable from the plastic cable clamp at the bottom of the DAT chassis.
10. Connect the tape drive power cable to the power supply.
11. Position the power supply in the DAT chassis. See Figure 2-7.
12. Install the screw (B in Figure 2-7) that holds the power supply to the rear of the DAT chassis.
13. Install the 2 screws (C in Figure 2-7) that hold the power supply to the bottom of the DAT chassis.
14. Connect the input power cable to the power supply.
15. Connect the SCSI input cable and the power cable to the rear of the DAT chassis.

Figure 2-7
DAT drive power supply

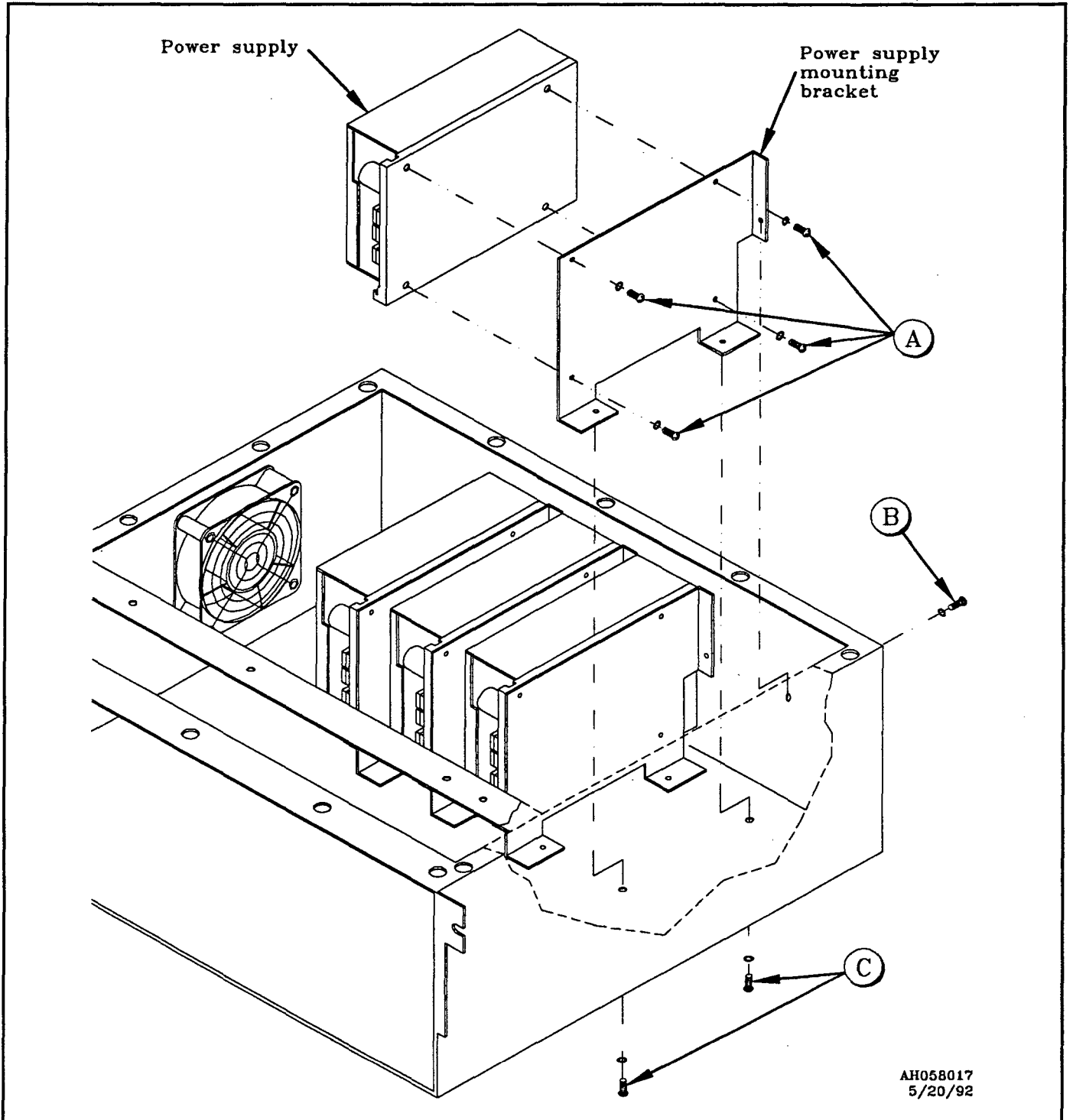

2.6 Installing a DAT drive

The following sections discuss the installation of a DAT drive into an existing DAT chassis.

2.6.1 Preinstallation

1. Do the preinstallation steps listed in Section 2.3 on page 2-3.
2. Set the DAT chassis power switch to the OFF position. See Figure 2-5.
3. Disconnect the cable from the SCSI host adapter and the power cable from the rear of the DAT chassis. See Figure 2-5.
4. Unlock the 2 captive screws holding the front panel of the DAT chassis and remove the panel.
5. Remove the 2 screws holding the DAT chassis to the front RETMA rails of the expansion cabinet.
6. Pull the DAT chassis out of the expansion cabinet until the side rails lock into place.
7. Remove the 14 captive screws that secure the top of the DAT chassis and remove the panel.
8. Remove, if present, all of the internal terminators from the DAT drive. See Figure 2-8.

Note

The DAT chassis internal SCSI cable (See Figure 4-14 on page 4-27) in the vertical-mount chassis is terminated. This termination will be in one of two different versions:

Version 1— Early production versions of the internal SCSI cable have a removable terminator on the fourth SCSI connector on the cable.

Version 2— Standard production versions of the internal SCSI cable have a permanent terminator attached a few inches beyond the fourth SCSI connector on the cable.

The internal SCSI cable for the horizontal-mount chassis does not have a terminator attached to it. The last chassis on a chain *must* have an external terminator installed. See Figure 4-16 on page 4-29.

Figure 2-8
Internal drive terminators

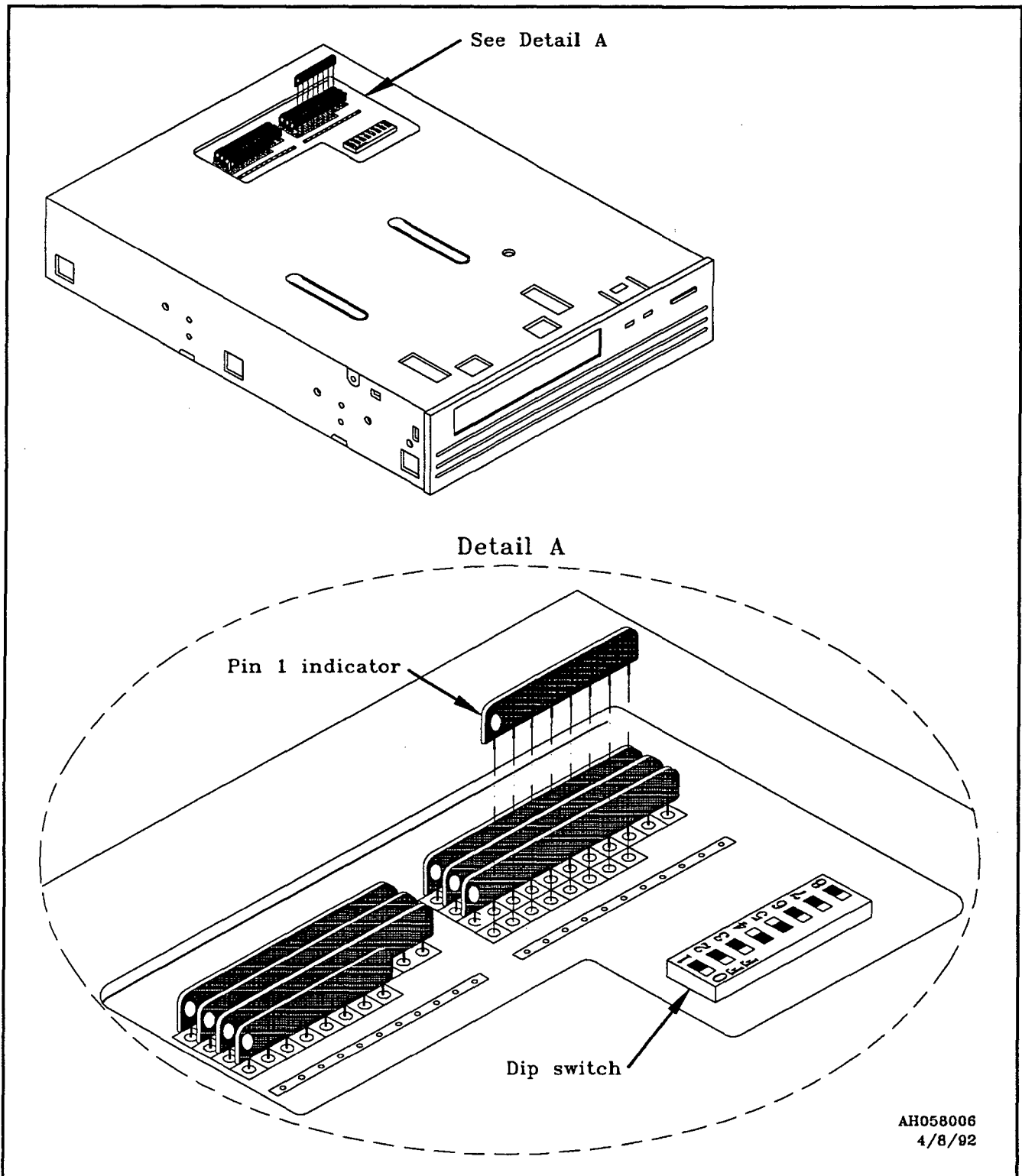

9. Check and, if necessary, change the SCSI address, the parity enable, and the self-test enable switch settings selected on the tape drive. Refer to Table 2-2 for the dip switch settings. See Figure 2-8 for the location of the dip switch.

Table 2-2
Dip switch settings with SCSI address

SCSI device address	S1	S2	S3	S4	S5	S6	S7	S8
	SCSI ID	SCSI ID	SCSI ID	SCSI-1 or SCSI-2 ¹	Parity enable ²	Comp-ression ³	Reserved	Self-test enable ⁴
0	OFF	OFF	OFF	ON	ON	OFF	OFF	ON
1	ON	OFF	OFF	ON	ON	OFF	OFF	ON
2	OFF	ON	OFF	ON	ON	OFF	OFF	ON
3	ON	ON	OFF	ON	ON	OFF	OFF	ON
4	OFF	OFF	ON	ON	ON	OFF	OFF	ON
5	ON	OFF	ON	ON	ON	OFF	OFF	ON
6	OFF	ON	ON	ON	ON	OFF	OFF	ON

¹ OFF = SCSI-1; ON = SCSI-2

² OFF = Parity disabled; ON = Parity enabled

³ Compression is enabled via software. Set switch ON for the AutoLoader or the manual-load drive with compression. Set the switch OFF for the manual-load drive without compression.

⁴ OFF = Self-test disabled; ON = Self-test enabled

Refer to one of the following for the procedure on selecting and setting the SCSI address:

- For the manual-load drive without compression (CONVEX part number 207-000017-200), *Archive Python DDS DAT Tape Drive Product Description Manual* (CONVEX part number 900-000601-001)
- For the manual-load drive with compression (CONVEX part number 207-000021-200), *Archive Python DDS-DC Data Compression DAT Tape Drive Product Description Manual* (CONVEX part number 900-000626-001)
- For the AutoLoader (CONVEX part number 207-000019-200), *Archive Python 4590T and 4592NP AutoLoader Product Description Manual* (CONVEX part number 900-000627-001)

2.6.2 Vertical-mount tape drive chassis

This section describes how to install the vertical-mount drives. See Section 2.6.3 for the installation procedures for the horizontal-mount and AutoLoader drives.

1. Position the tape bracket on the DAT drive and install the 2 screws that hold the bracket to the drive (C in Figure 2-9).
2. Position the drive in the selected slot of the DAT chassis.
3. Install the 2 screws (B in Figure 2-9) that hold the DAT drive to the bottom of the DAT chassis.
4. Install the screw (A in Figure 2-9) that holds the DAT drive to the top of the DAT chassis.
5. Do the postinstallation steps listed in Section 2.6.4 on page 2-19.

Figure 2-9
Vertical-mount drive position in DAT chassis

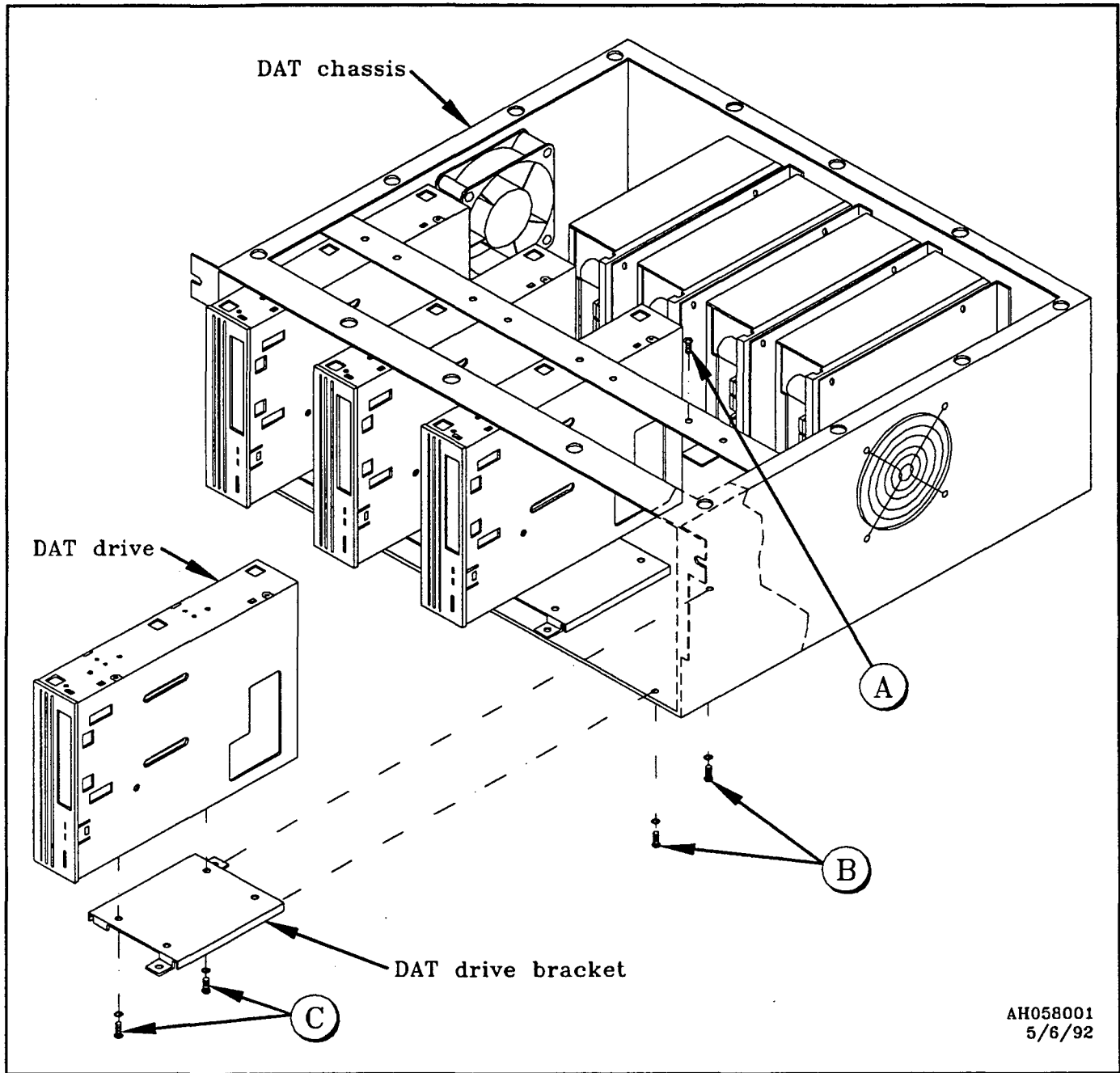

2.6.3 Horizontal-mount tape drive chassis

Note

Refer to the *Archive Python 4590NT/4592NP Product Description Manual* for more information on the AutoLoader. Refer to the *Archive Python DDS-DC Data Compression DAT Tape Drive Product Description Manual* for more information on the AutoLoader.

If the chassis contains only one drive, either regular or AutoLoader, it must go in the bottom left position because of cable limitations.

The AutoLoader(s) must go in the bottom position(s) in the chassis to provide for movement of the magazine.

No tape drive can be installed in the chassis above the AutoLoader(s) to provide for movement of the magazine.

The maximum allowed configurations are as follows:

- 4 manual-load and 0 AutoLoader
- 2 manual-load and 1 AutoLoader
- 0 manual-load and 2 AutoLoaders

Use the following procedure to install either a horizontal-mount or AutoLoader disk drive into an existing chassis:

1. Remove the 2 screws (A in Figure 2-10) holding each DAT drive bracket to the DAT chassis and remove the brackets from the chassis.
2. Position a tape bracket on either side of the DAT drive and install the 2 screws that hold each bracket to the drive (B in Figure 2-10).

Note

There are 2 sets of holes on the side of the AutoLoader and the manual-load drive; install the screws in the top two holes. Failure to do so will not allow the front panel to fit onto the chassis.

3. Position the drive in the selected slot of the chassis.
4. Install the 2 screws (A in Figure 2-10) in each of the brackets to attach them to the bottom of the DAT chassis.
5. Do the postinstallation steps listed in Section 2.6.4 on page 2-19.

Figure 2-10
Horizontal drive installation in chassis

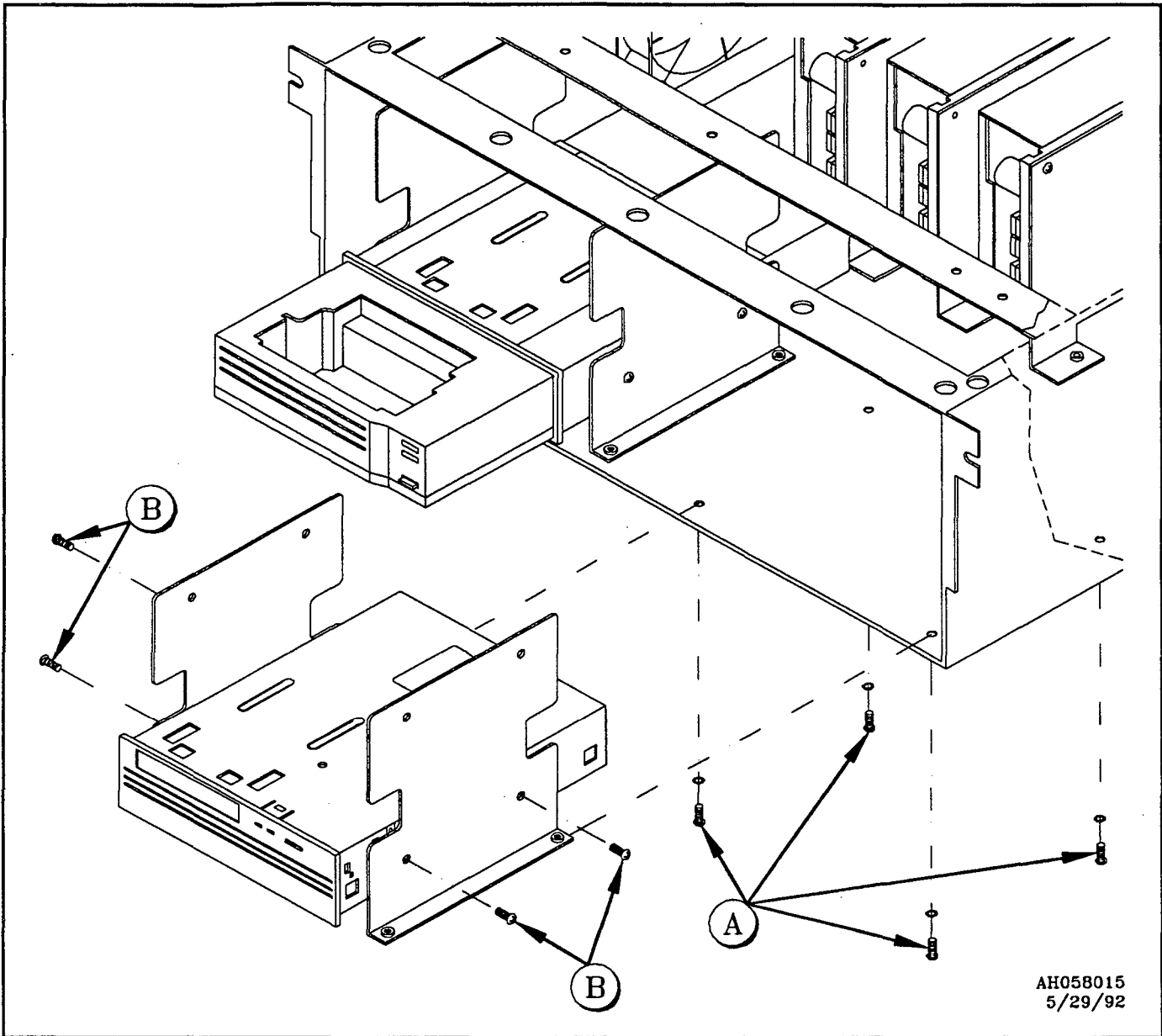

2.6.4 Postinstallation

This section gives steps to be done after installing a DAT drive and brackets into a DAT chassis.

1. Connect the SCSI ribbon cable to the back of the drive.
2. Connect the power cable from the power supply to the back of the DAT drive.
3. Position the top panel on the DAT chassis and lock the 14 captive screws in place.
4. On a horizontal-mount chassis, install a terminator on the last chassis in a daisy chain.
5. Connect the SCSI input cable and the power cable to the rear of the DAT chassis.
6. On the back of the DAT chassis, set the chassis power switch to the ON position.
7. Slide the DAT chassis back to its retracted position.
8. Install the 2 screws that hold the DAT chassis in the expansion cabinet.
9. Remove appropriate insert(s) from front panel.
10. Position the front panel on the DAT chassis and secure the 2 captive screws.
11. Do the postinstallation steps listed in Section 2.7.

2.7 Postinstallation

This section gives steps to be done after a DAT system installation:

1. Return the expansion cabinet stabilizer bars to their retracted position.
2. Return power to the VMEbus chassis.
3. Return power to the expansion cabinet.
 - To return power to a CONVEX EXP-101 or EXP-102 expansion cabinet, connect the power cord to the site source.
 - To return power to a CONVEX EXP-105 high-performance expansion cabinet, set the main power control switch to the ON position.
4. Turn the processor's front panel keyswitch to the ON position.

2.8 Installing a cartridge magazine

The following procedure describes how to install a cartridge magazine into an AutoLoader tape drive. See Figure 2-11 for details.

1. Insert each cassette into the magazine with the arrow on the cassette pointing outward. The cassette should firmly install into the magazine.
2. Align the magazine with the holder so that the cassettes face into the main portion of the tape drive.
3. Place the magazine into the holder. You should hear a click when the magazine is properly installed. The magazine will only sit partially in the holder. It may also tilt slightly.

The AutoLoader then automatically loads and initializes the magazine.

Note

The AutoLoader automatically initializes a blank DAT cassette being written for the first time. This process takes about 45 seconds; do not eject the cassette during this time.

To unload the magazine, press and hold the load/unload button for several seconds, then lift the magazine out of the holder.

Figure 2-11
Cartridge magazine installation

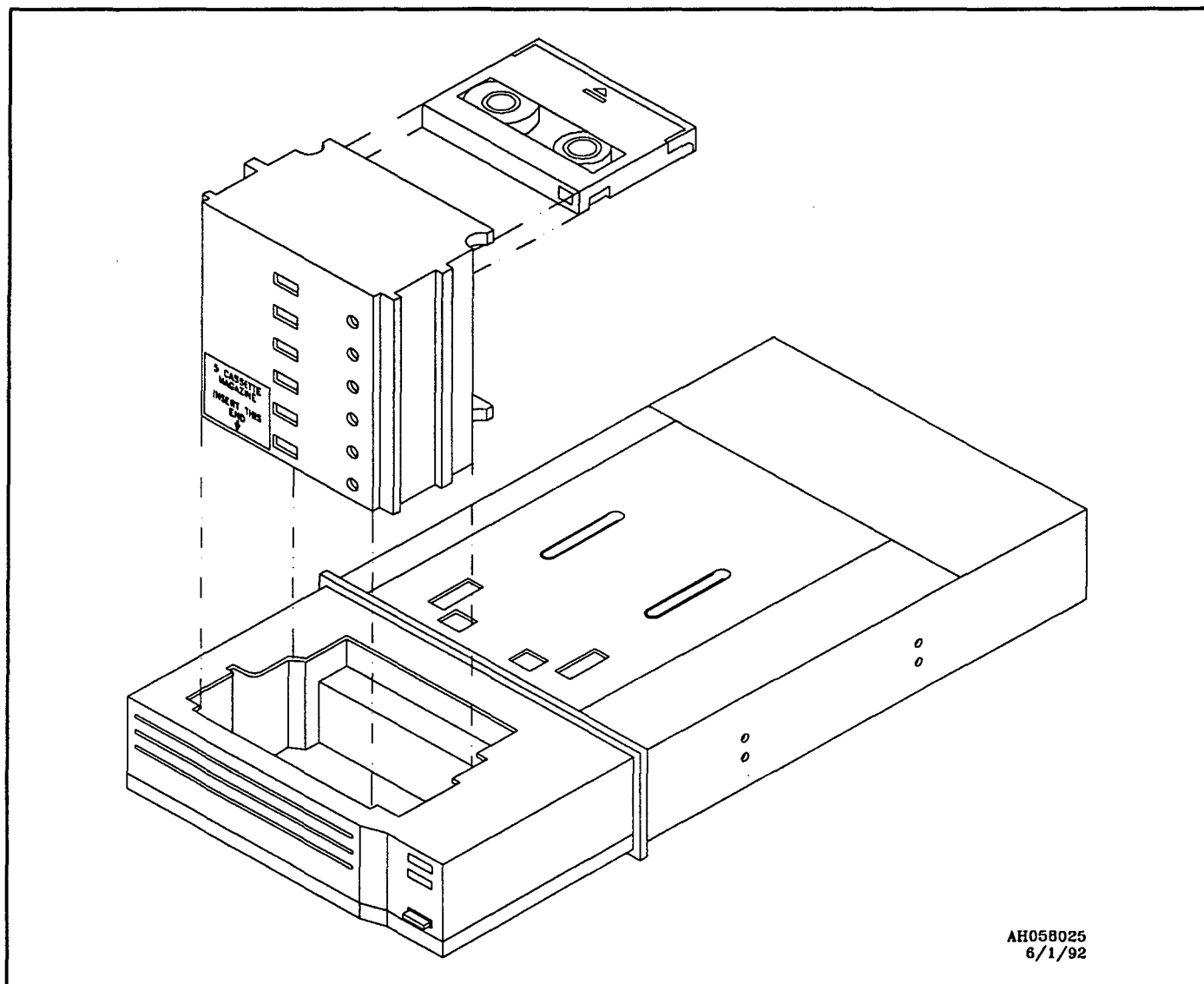

3.1 Overview

The CONVEX digital audio tape (DAT) drive system must be integrated into the CONVEX operating system (ConvexOS) before it can be used. This chapter contains guidelines for integrating a DAT drive into ConvexOS as well as information on the CONVEX diagnostic tests for the DAT drive system.

Notes

ConvexOS V8.1 or greater is required to operate a CONVEX DAT drive system.

ConvexOS V8.1 and V9.0 require a system generation of the software drivers when a SCSI host adapter and DAT drive system are installed.

Versions of ConvexOS later than V9.0 contain all the software drivers needed for the SCSI host adapter. This means a system generation is not required when a SCSI host adapter and DAT drive system are installed.

ConvexOS V10.1 or greater is required for the Autoloader and data compression.

3.2 Software integration

The software for the CONVEX DAT drive system is released separately from ConvexOS and utilities. Refer to the *ConvexOS System Manager's Guide* for additional software integration information. That document includes a complete description of the software integration procedures for DAT drive system software.

System-level hardware is identified to ConvexOS via a configuration file (`/ioconfig`) located on the service processor unit (SPU) disk. The `/ioconfig` file describes, in hierarchical fashion, the connections between VIOPs, VMEbus chassis number, controller type, control and status register (CSR) address, interrupt number, and peripheral device type. The device codes for the DAT drive system are listed below:

- MTC-202—SCSI host adapter
- MTD-208—DAT manual-load drive system
- MTD-228—DAT manual-load drive system with data compression
- MTD-238—DAT AutoLoader drive system

Figure 3-1 shows a typical /ioconfig file with the following configuration:

- Units 0 through 3 are manual-load drives in the same chassis.
- Unit 4 is a manual-load drive with compression in a separate chassis.
- Unit 5 is an AutoLoader drive in another chassis.
- The two chassis containing units 4 and 5 are daisy-chained with the chassis containing Units 0-3.

The entries specific to the DAT drive and SCSI host adapter are highlighted.

Figure 3-1
Example /ioconfig file

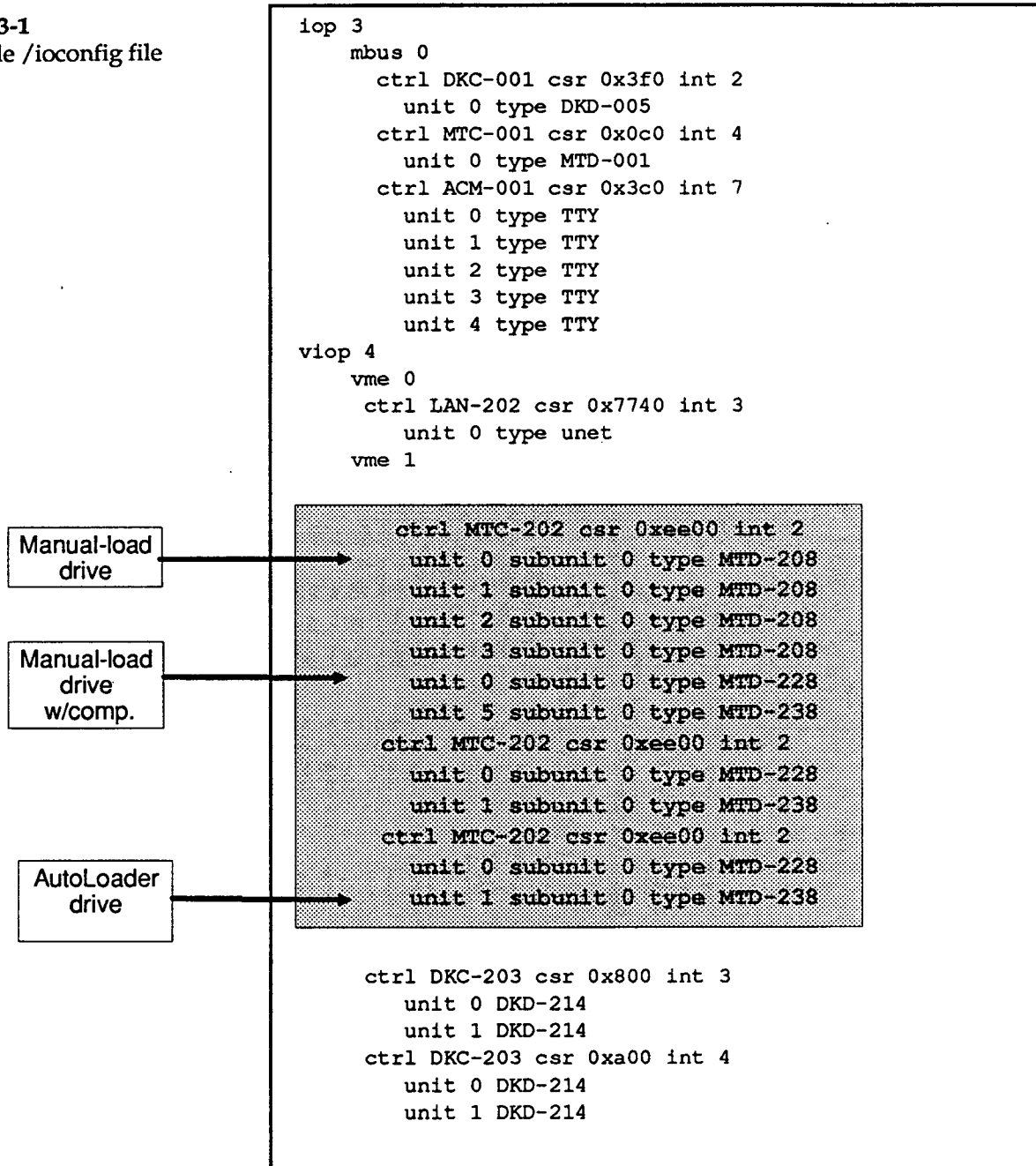

Whenever DAT drives are added or removed, the information in the hardware section of the configuration file (/ioconfig) must be changed, otherwise system operation problems will occur. Refer to *Managing ConvexOS : Operations Guide* when making these changes.

3.3 Testing the DAT drive

The CONVEX DAT tape system is tested by the *dev_vscsit* diagnostic program. This program verifies the operation of the DAT drive system. The *dev_vscsit* diagnostic program verifies the:

- Functional ability of the SCSI host adapter to operate in the CONVEX VMEbus I/O environment, including main memory access and interrupt generation and detection
- Ability of the host adapter to detect anomalous conditions on the SCSI bus
- Operational integrity of the cable interface between the DAT drive and the tape unit

The *dev_vscsit* diagnostic program is an offline program that must be executed on the SPU while the CPU is halted. The procedures for executing this test are beyond the scope of this manual. This information is contained in the *CONVEX VMEbus DAT/3480 Tape Subsystem Diagnostics Manual*; consult this manual before running CONVEX diagnostics.

4.1 Overview

This chapter gives information on preventive maintenance, removal and replacement procedures, an illustrated parts breakdown (IPB), and CONVEX part numbers for the CONVEX DAT system.

4.2 Preventive maintenance

This section gives information on the preventive maintenance schedules and procedures for the DAT drive.

4.2.1 DAT drive front panel LEDs

The front panel of the DAT drive contains two light-emitting diodes (LEDs). The amber LED indicates the drive status. The green LED indicates the cassette status. See Figures 4-1 and 4-2 and Table 4-1.

Figure 4-1
Manual-load DAT drive LED indicators

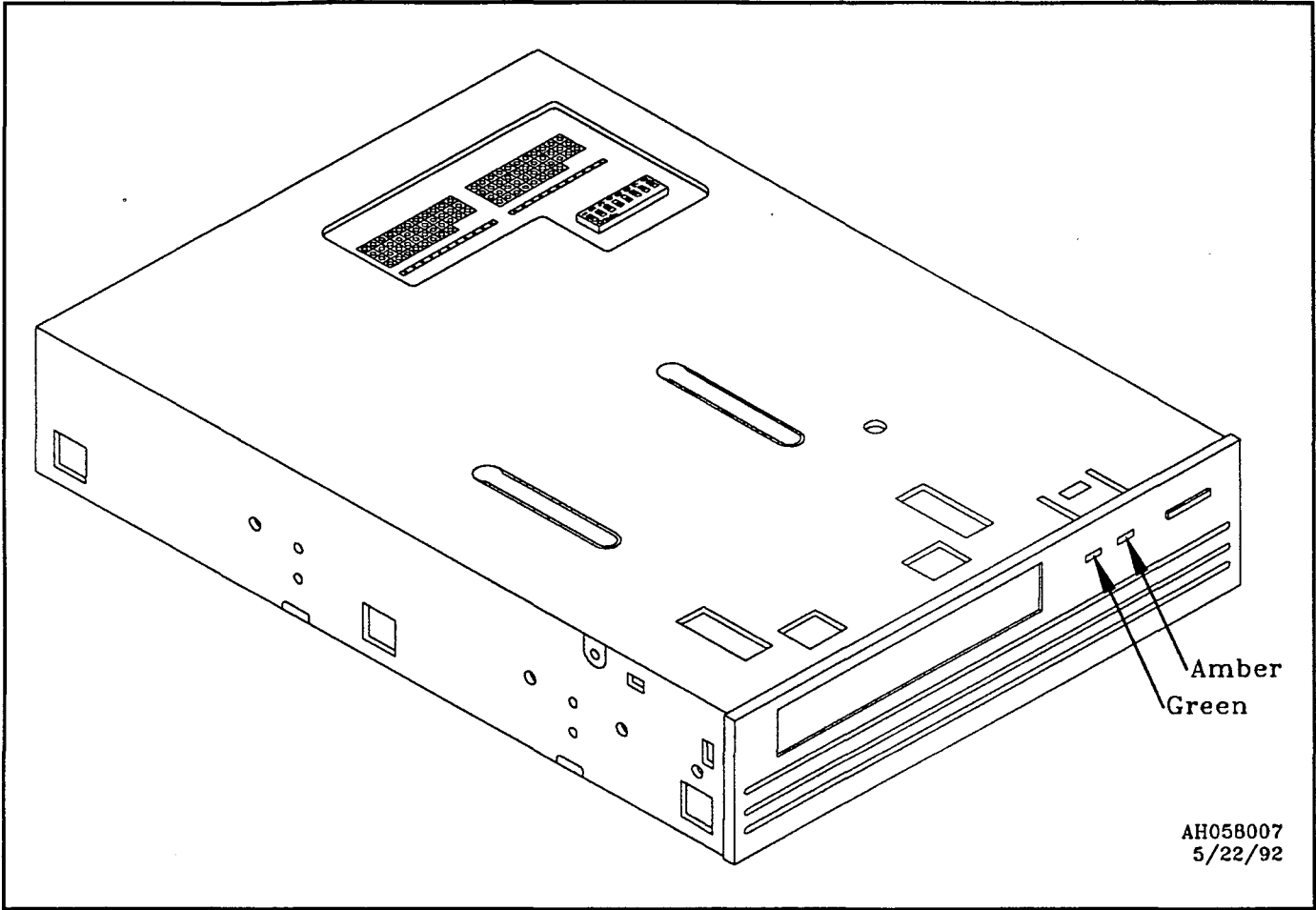

Figure 4-2
AutoLoader drive LED indicators

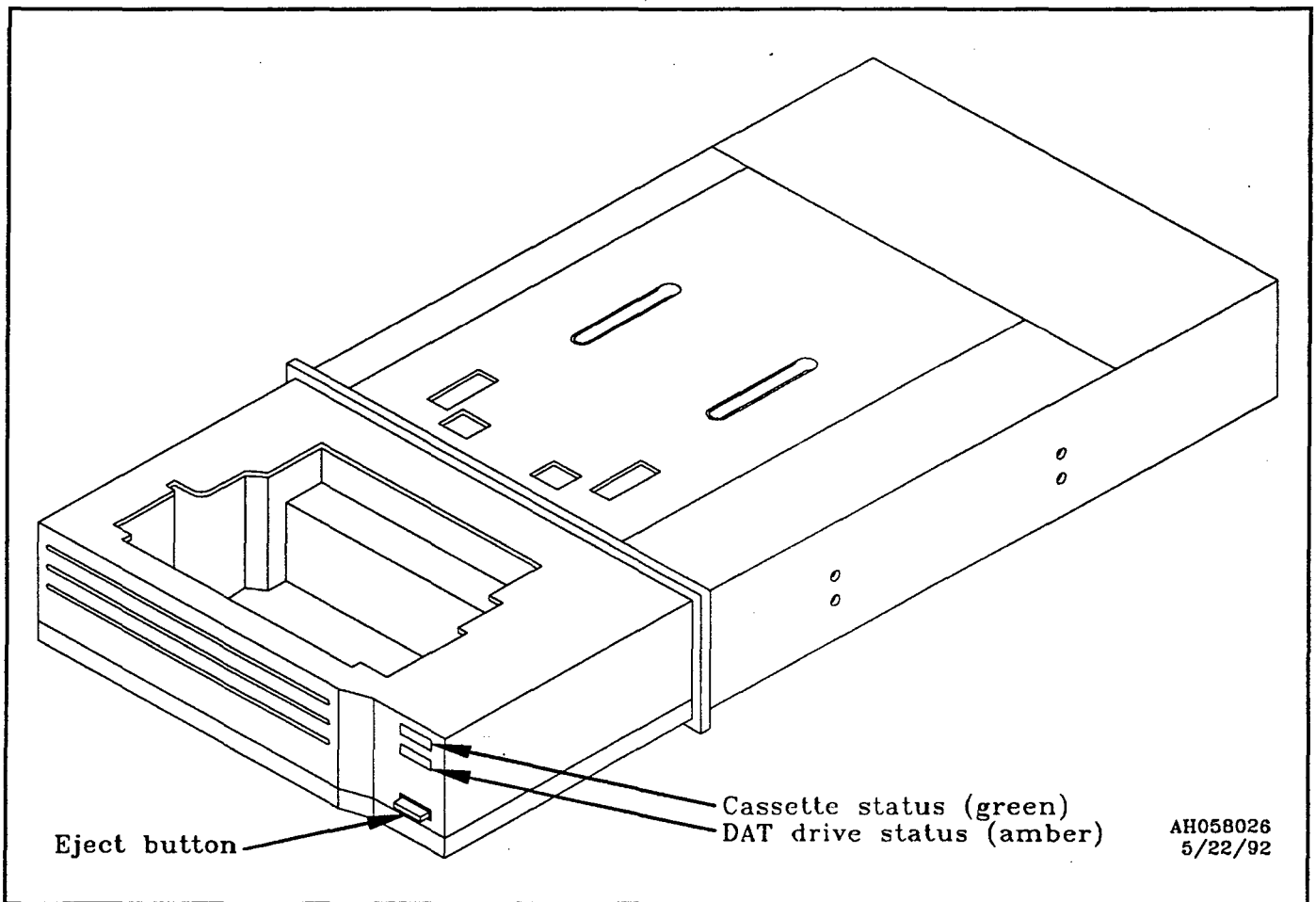

Table 4-1
DAT drive LED indicators

LED	Action	Description
Amber	On	The drive is active.
Amber	Blinking rapidly	Hardware fault has occurred or condensation was detected.
Green	On	A DAT cassette is inserted.
Green	Blinking slowly	A DAT cassette is inserted and generates excessive errors.
Green	Blinking slowly (with amber LED blinking)	A prerecorded audio cassette is inserted and played automatically.
Green	Blinking rapidly	The drive could not write the tape correctly or the cleaning cassette being used has reached the end of its life.

4.2.2 Cleaning the DAT drive

Whenever the green LED blinks slowly, the DAT drive heads should be cleaned with the cleaning cassette. Cleaning cassettes are shipped with each DAT chassis. Cleaning is recommended after 50 hours of operation even if the drive does not indicate it is required.

Notes

A blinking green LED may indicate a damaged DAT cassette or a data cassette nearing the end of its life. If cleaning the DAT drive heads does not correct the blinking LED, replace the data cassette currently in use.

To clean the DAT drive heads insert the cleaning cassette. The DAT drive will automatically run the cassette approximately 10 seconds and eject the tape.

Note

A DAT cleaning cassette has approximately 100 uses, after which it should be replaced. When a cleaning cassette has reached the end of its life, it will be ejected immediately after insertion. When this occurs, discard the cleaning cassette.

4.2.3 Removing cassettes manually

Refer to one of the following for the procedure on how to manually remove a cassette from a DAT drive.

- For the manual-load drive without compression (CONVEX part number 207-000017-200), refer to *Archive Python DDS DAT Tape Drive Product Description Manual*, Chapter 3, "Functional Description," subsection "Unloading A Cassette (Manual Operation)."
- For the manual-load drive with compression (CONVEX part number 207-000021-200), refer to *Archive Python DDS-DC Data Compression DAT Tape Drive Product Description Manual*, Chapter 4, Section 4.4, "Loading/Unloading the Cassette."
- For the AutoLoader (CONVEX part number 207-000019-200), *Archive Python 4590T and 4592NP AutoLoader Product Description Manual*, Chapter 4, Section 4.6, "Loading/Unloading a Single Cassette."

4.3 Preservice procedures

This section gives procedures that need to be performed before continuing with any of the removal or replacement procedures.

Caution

Power *must* be removed from the VMEbus chassis before disconnecting and connecting the SCSI host adapter to the DAT chassis. Failure to do so will cause damage to equipment.

1. Set the VMEbus chassis power control switch to the OFF position. See Figure 4-3.

Figure 4-3 .
VMEbus chassis power control switch

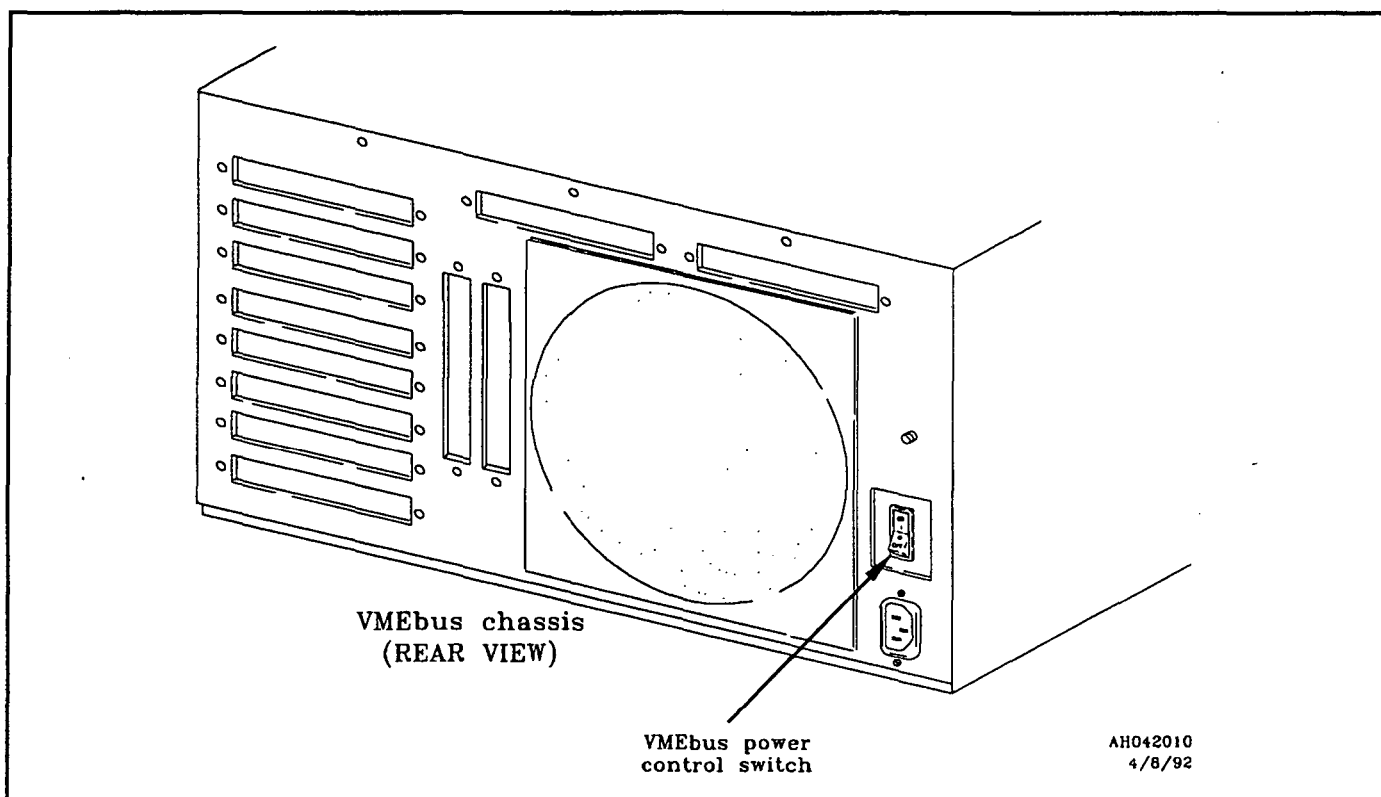

Caution

Remove power to the expansion cabinet before removing or servicing any equipment. Failure to do so will cause damage to electronic equipment components.

2. Remove power to the expansion cabinet.

- To remove power from a CONVEX EXP-101 or EXP-102 expansion cabinet, disconnect the power cord from the power source.
- To remove power from a CONVEX EXP-105 high-performance expansion cabinet, set the main power control switch to the OFF position.

Warning

Expansion cabinet stabilizer bars *must* be extended prior to extending any component installed in the expansion cabinet. Failure to do so will make the expansion cabinet unstable, increase the possibility of it falling forward, can cause injury to personnel, and will cause damage to equipment.

3. Extend the expansion cabinet stabilizer bars and adjust the feet until they are in firm contact with the floor. See Figure 4-4.

Figure 4-4
Expansion cabinet stabilizer bars

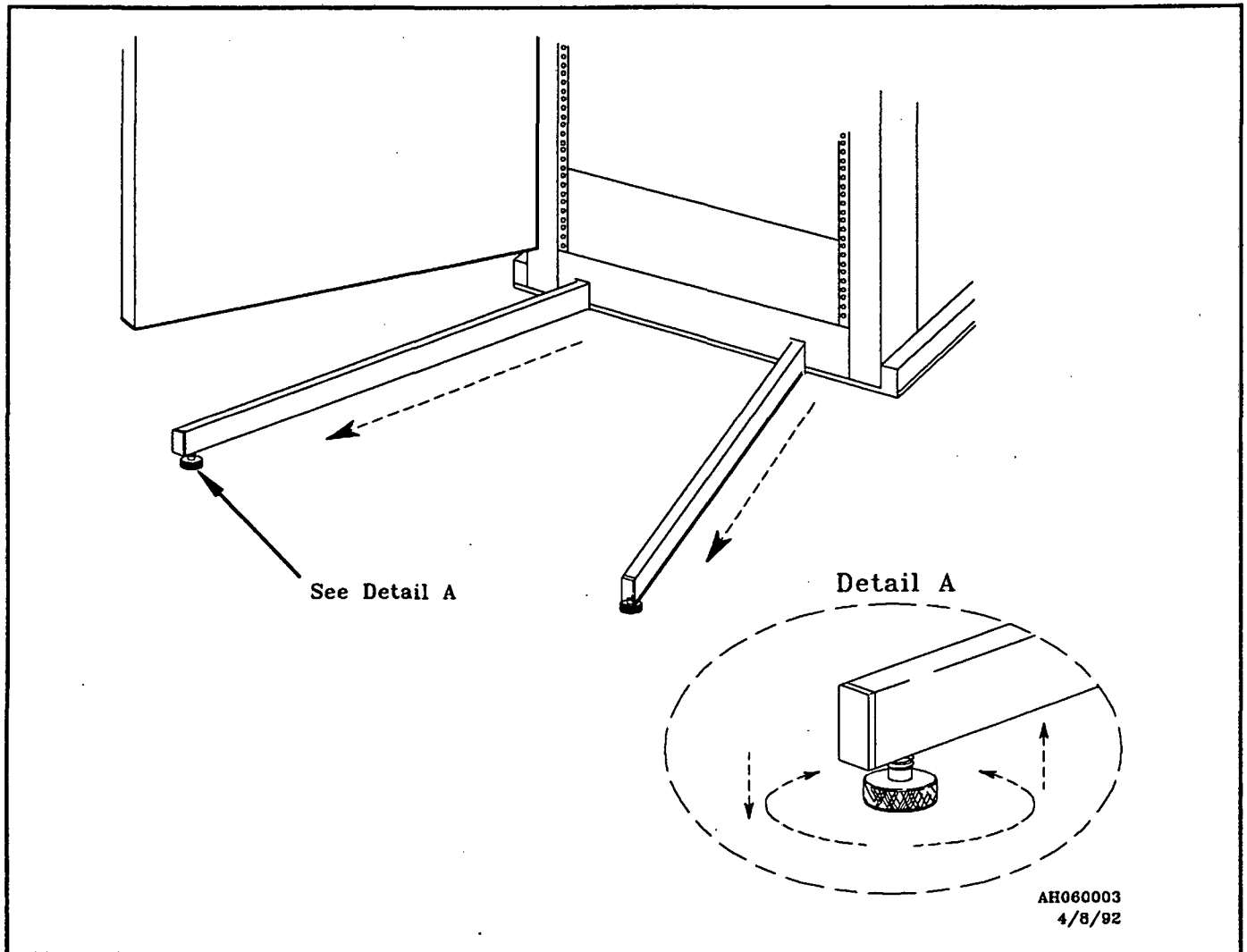

4. On the back side of the DAT chassis, set the power switch to the OFF position. See Figures 4-5 and 4-6.
5. Disconnect the input cable from the SCSI host adapter and the power cable from the rear of the DAT chassis. See Figures 4-5 and 4-6.
6. Unlock the 2 captive screws on the front panel of the DAT chassis and remove the panel.
7. Remove the 2 screws holding the DAT chassis in the expansion cabinet.
8. Pull the DAT chassis out of the cabinet until the side rails lock into position.
9. Remove the 14 captive screws that secure the top panel of the DAT chassis and remove the panel.

Figure 4-5
Vertical-mount chassis rear panel

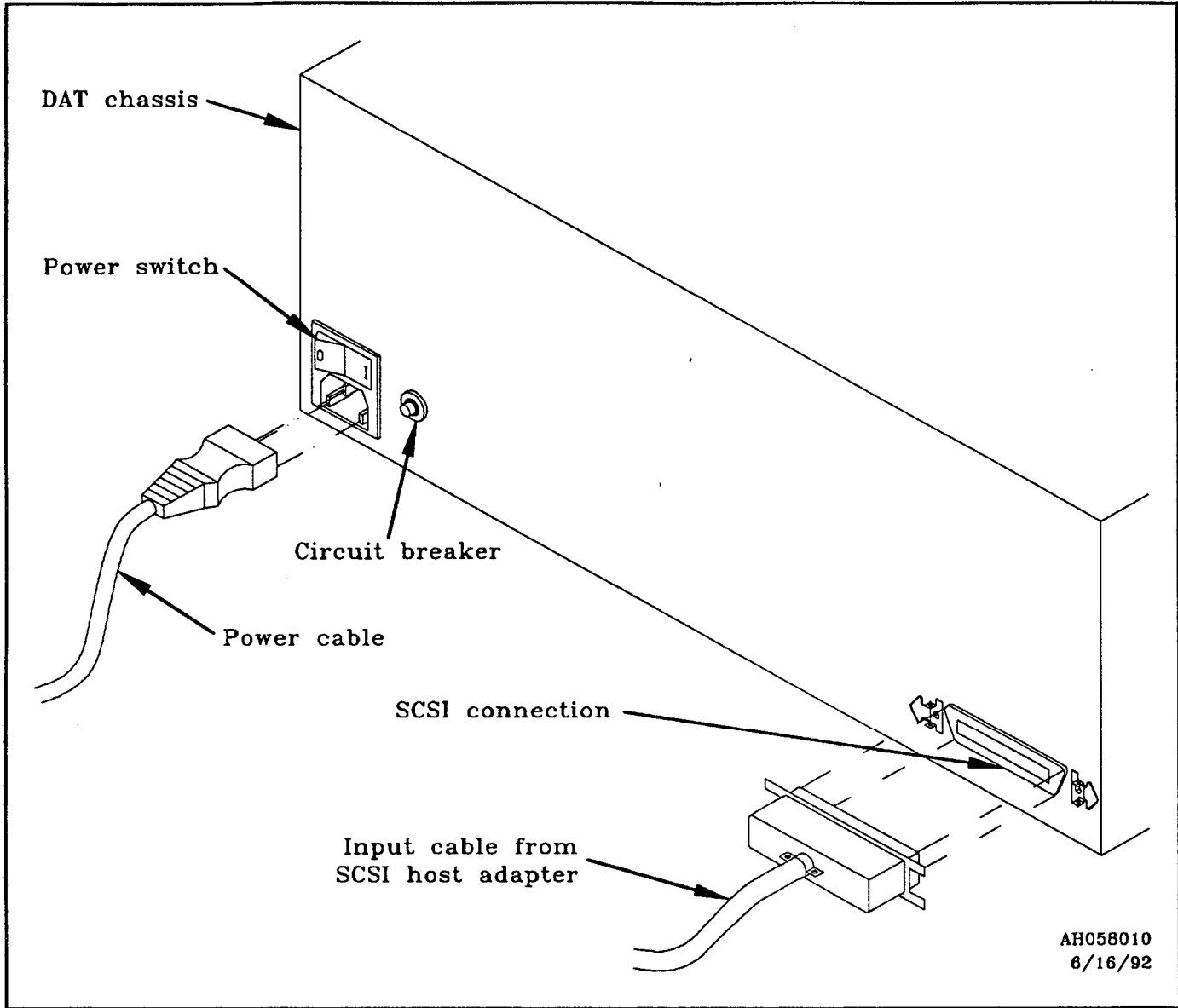
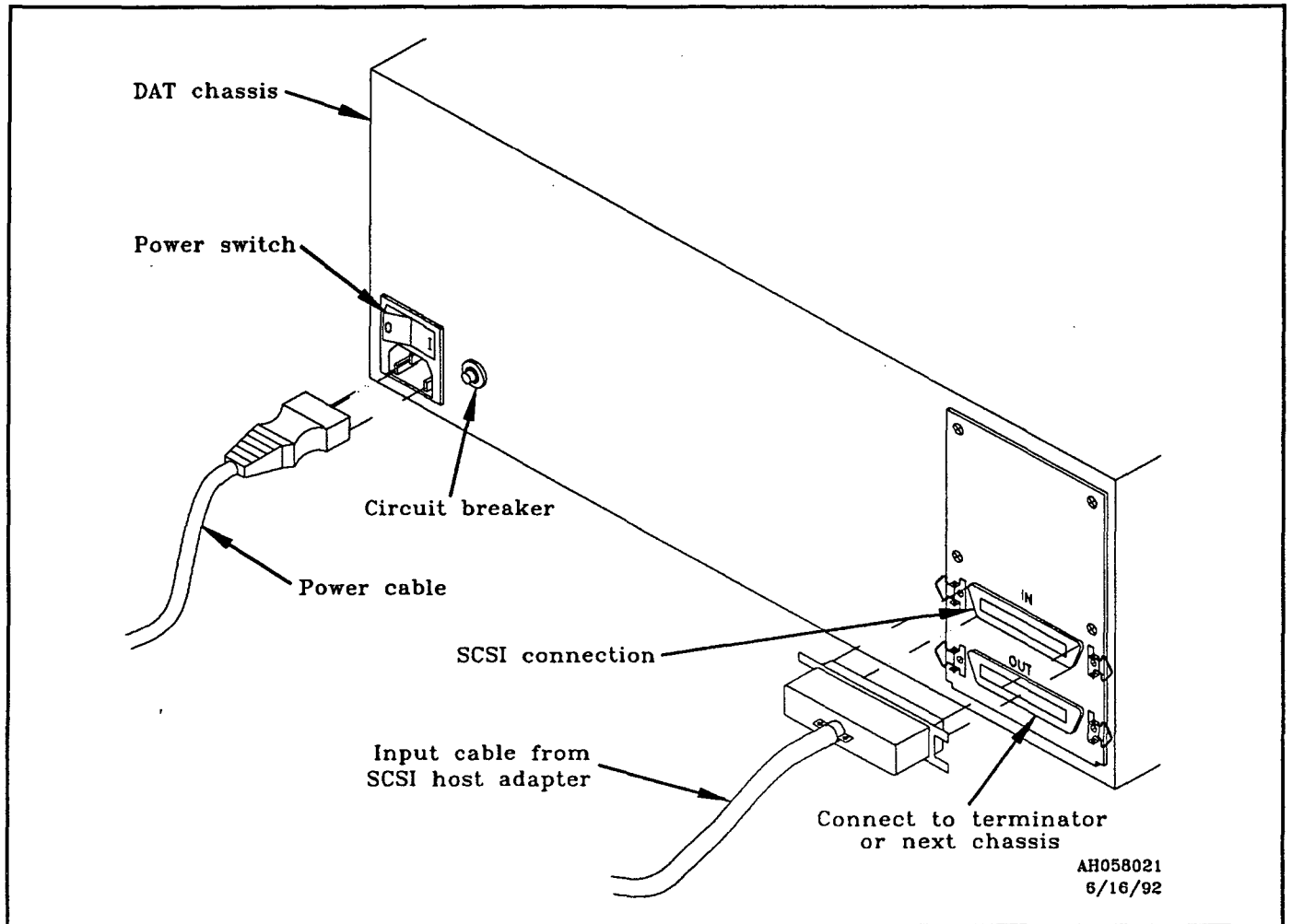

Figure 4-6
Horizontal-mount chassis rear panel



4.4 Vertical-mount drive

This section gives the procedure for removing and replacing the vertical-mount drive. See Figure 4-7.

Figure 4-7
Vertical-mount DAT drive unit

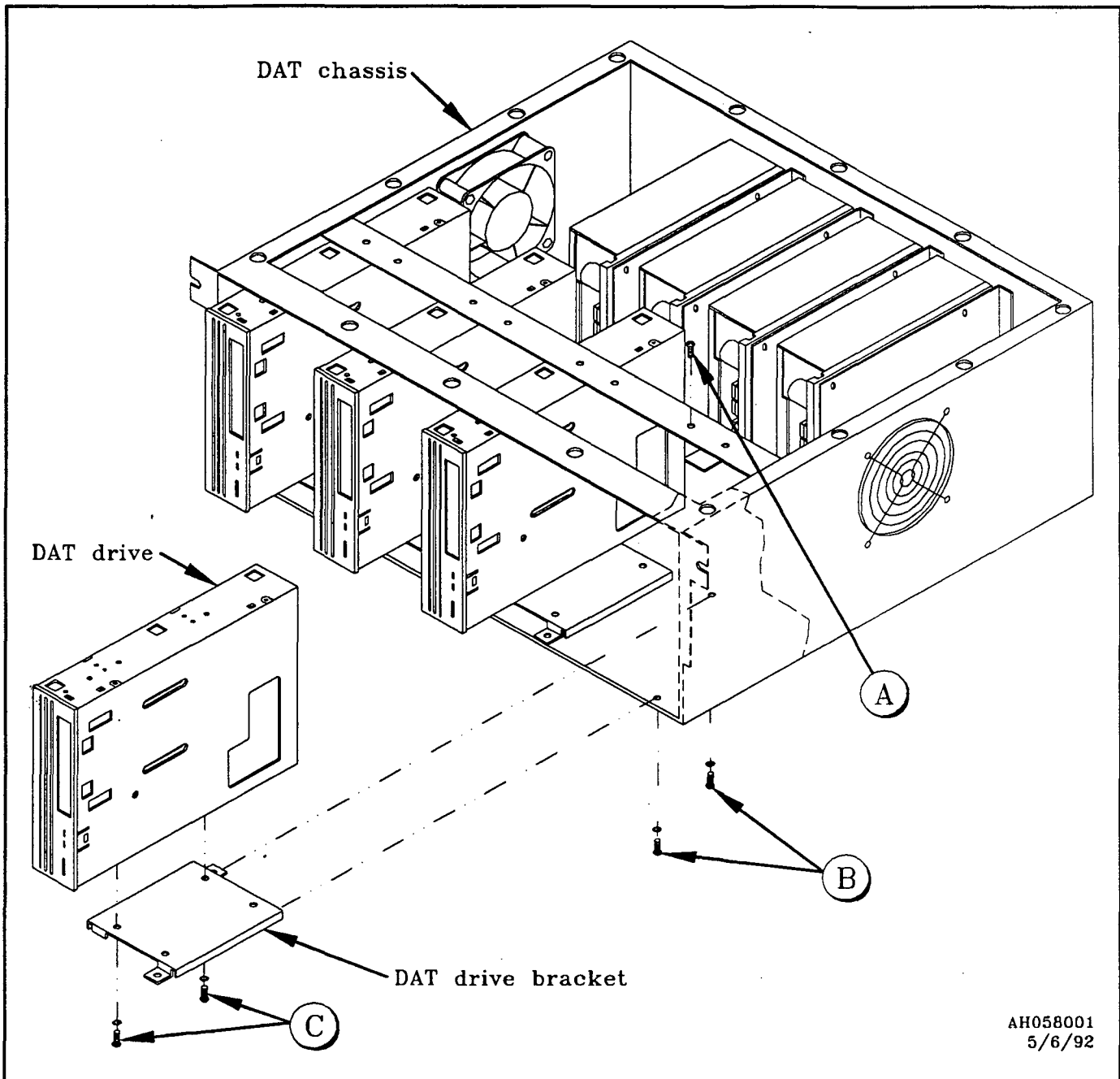

4.4.1 Removal

1. Do the preservice procedures listed in Section 4.3 on page 4-5.
2. Remove the screw (A in Figure 4-7) holding the DAT drive to the top of the DAT chassis.
3. Remove the 2 screws (B in Figure 4-7) holding the DAT drive bracket to the DAT chassis.
4. Remove the DAT drive.
5. Remove the 2 screws (C in Figure 4-7) holding the bracket to the DAT drive.

4.4.2 Replacement

Note

Refer to the *Archive Python DDS-DC Data Compression DAT Tape Drive Product Description Manual* for procedures on selecting and setting the SCSI address on the DAT drive.

1. Check, and, if necessary, change to match replaced drive, the SCSI address, the parity enable, and the self-test enable switch settings selected on the dip switch of the DAT drive. See Table 2-2 on page 2-14.
2. Remove, if present, all the internal terminators from the new DAT drive. See Figure 4-8.

Note

The DAT chassis internal SCSI cable (see Figure 4-15 on page 4-28) is terminated. This termination will be in one of two different versions:

Version 1—Early production versions of the internal SCSI cable will have a removable terminator on the fourth SCSI connector on the cable.

Version 2—Standard production versions of the internal SCSI cable will have a permanent terminator attached a few inches beyond the fourth SCSI connector. See Figure 4-15 on page 4-28 .

Figure 4-8
DAT drive terminators

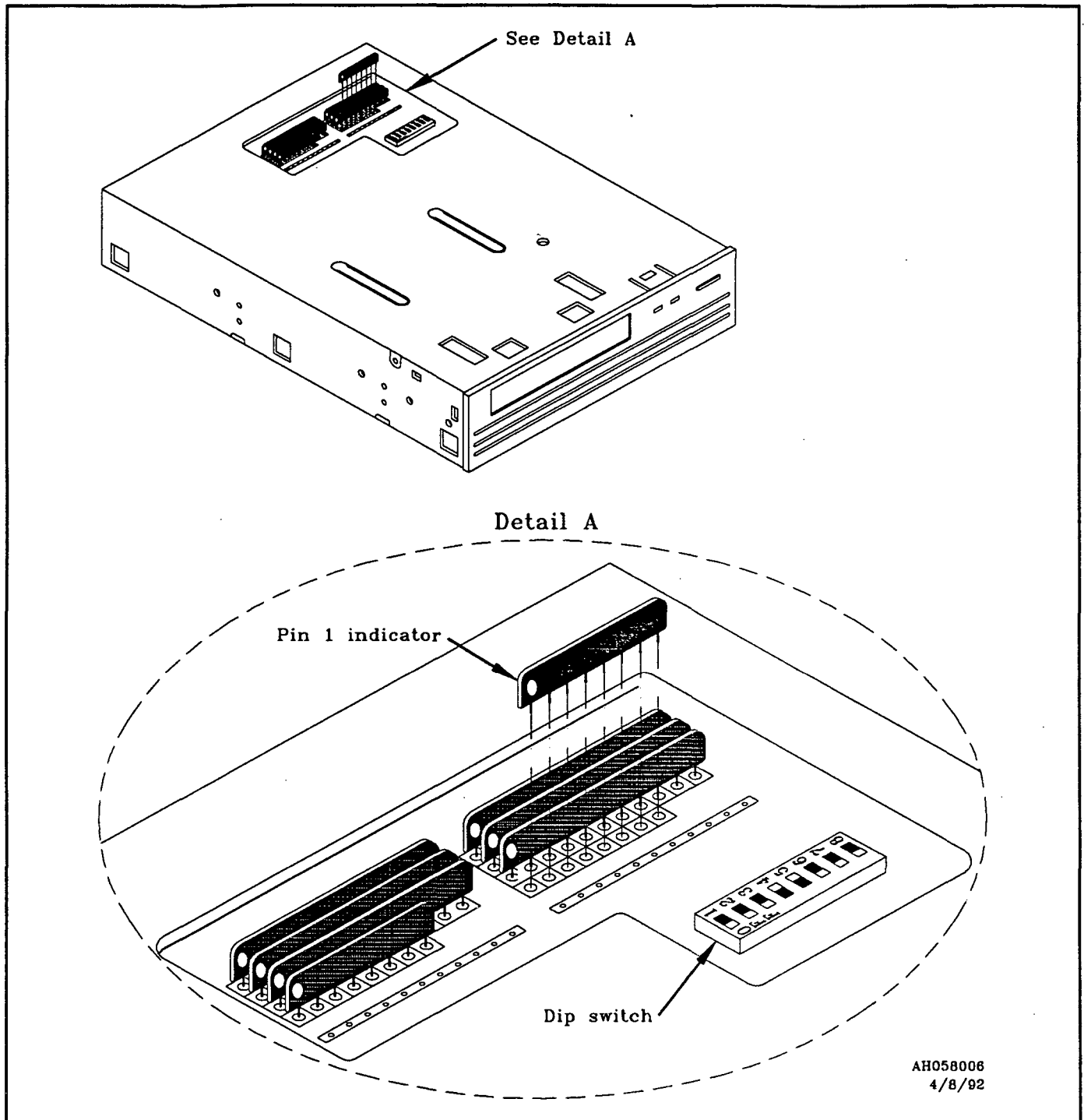

3. Position the tape bracket on the drive and install the 2 screws (C in Figure 4-7) that hold the bracket to the drive.
4. Position the drive in the selected slot of the chassis.
5. Install the screw (A in Figure 4-7) that holds the DAT drive to the top of the DAT chassis.
6. Install the 2 screws (B in Figure 4-7) that hold the drive to the bottom of the chassis.
7. Install the screw (A in Figure 4-7) that holds the drive to the top of the chassis.
8. Connect the SCSI ribbon cable to the back of the DAT drive.
9. Connect the power cable to the back of the DAT drive.
10. Do the postservice procedures listed in Section 4.11 on page 4-21.

4.5 Horizontal-mount or AutoLoader tape drive

This section gives the procedure for removing and replacing the horizontal-mount or AutoLoader tape drive. See Figure 4-9.

Note

Refer to the *Archive Python 4590T and 4592NP AutoLoader Product Description Manual* for more information on the AutoLoader.

Figure 4-9
Horizontal-mount DAT drive unit

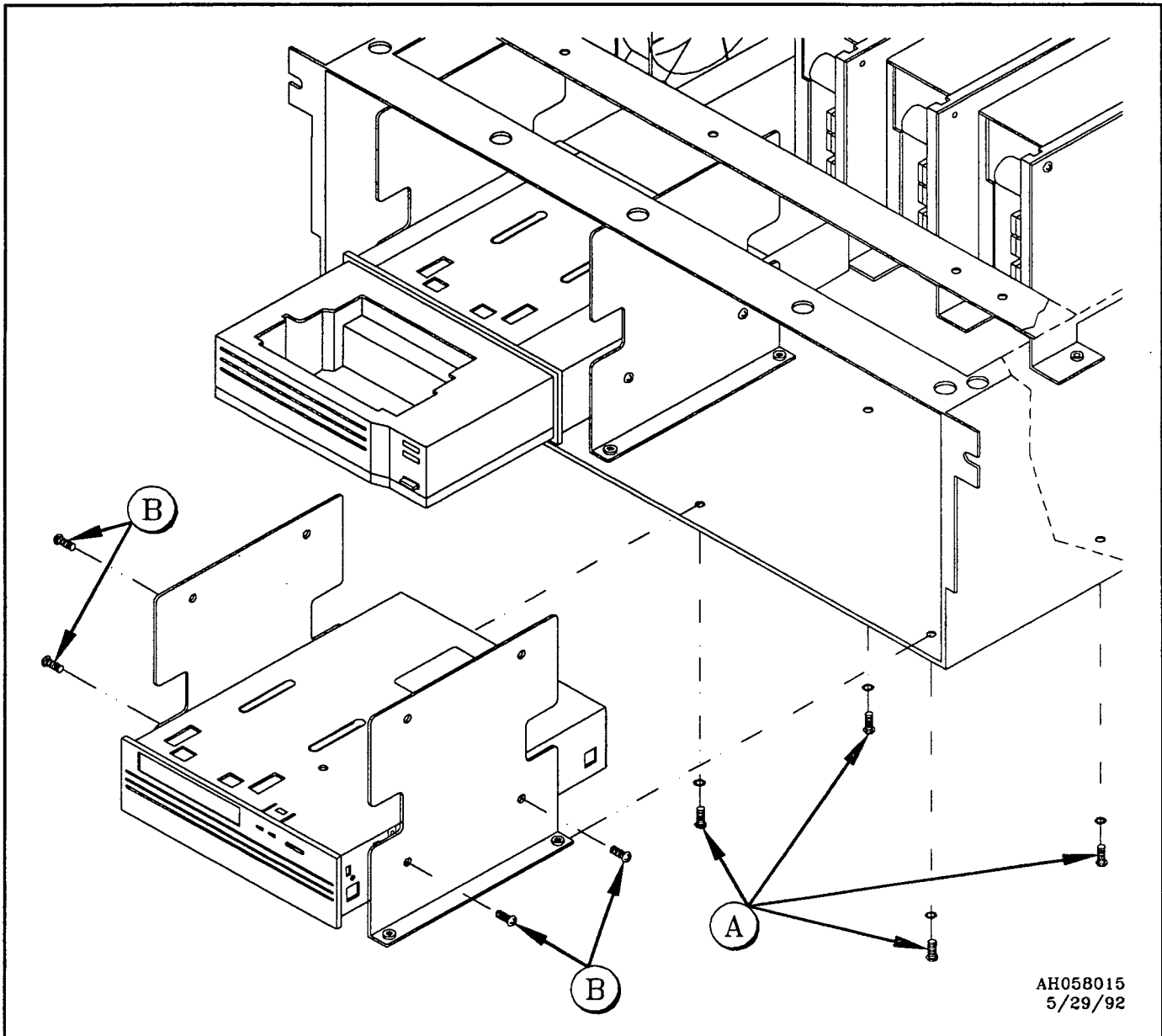

4.5.1 Removal

1. Do the preservice procedures listed in Section 4.3 on page 4-5.
2. Remove the 2 screws (A in Figure 4-9) holding each bracket to the DAT chassis.
3. Remove the drive and bracket from the chassis.
4. Remove the 2 screws (B in Figure 4-9) holding each bracket to the drive being replaced.

4.5.2 Replacement

Note

Refer to the *Archive Python 4590T and 4592NP AutoLoader Tape Drive Product Description Manual* for procedures on selecting and setting the SCSI address on the DAT drive.

1. Check, and, if necessary, change to match replaced drive, the SCSI address, the parity enable, and the self-test enable switch settings selected on the dip switch of the DAT drive. See Table 2-2 on page 2-14.
2. Position a bracket on either side of the new drive and install the 2 screws that hold each bracket to the drive (B in Figure 4-9).

Note

There are 2 sets of holes on the side of the AutoLoader; install the screws in the top two holes. Failure to do so will not allow the front panel to fit onto the chassis.

3. Position the drive in the selected slot of the chassis.
4. Install the 2 screws (A in Figure 4-9) in the bottom of each bracket that attach them to the bottom of the DAT chassis.
5. Connect the SCSI ribbon cable and the power cable to the back of the DAT drive.
6. Do the postservice procedures listed in Section 4.11 on page 4-21.

4.6 DAT drive power supply

This section gives procedures for removing and replacing the DAT drive power supplies. See Figure 4-10.

4.6.1 Removal

1. Do the preservice procedures listed in Section 4.3 on page 4-5.
2. Remove power cable from the DAT drive.
3. If necessary, uncouple the cable going to the fans.
4. Disconnect the input power cable from the power supply.
5. Remove the 2 screws (C in Figure 4-10) connecting the power supply to the bottom of the DAT chassis.
6. Remove the screw (B in Figure 4-10) connecting the power supply to the rear of the DAT chassis.
7. Remove the power supply from the DAT chassis.
8. Remove the 4 screws (A in Figure 4-10) connecting the power supply to the power supply bracket.

4.6.2 Replacement

1. Install the 4 screws (A in Figure 4-10) that attach the power supply to the power supply bracket.
2. Connect the tape drive power cable to the power supply.
3. Position the power supply in the chassis.
4. Install the screw (B in Figure 4-10) that holds the power supply to the rear of the DAT chassis.
5. Install the 2 screws (C in Figure 4-10) that hold the power supply to the bottom of the DAT chassis.
6. Connect the input power cable to the power supply.
7. If necessary, connect the cable going to the fans.
8. Do the postservice procedures listed in Section 4.11 on page 4-21.

Figure 4-10
DAT drive power supply

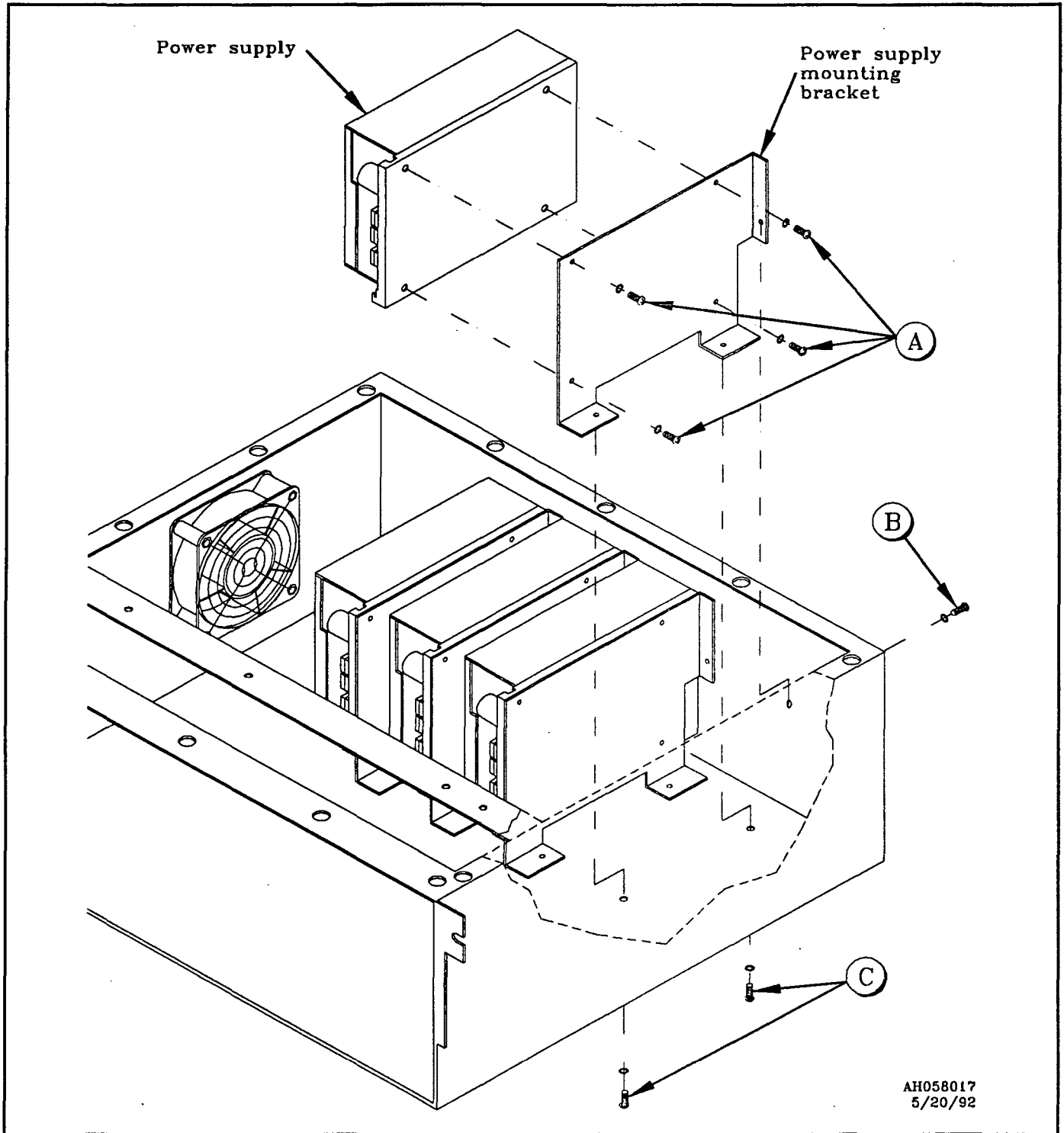

4.7 DAT chassis cooling fan

This section gives the procedures for removing and replacing the cooling fan in the DAT chassis. See Figure 4-11.

Figure 4-11
DAT chassis fan and power control FRUs

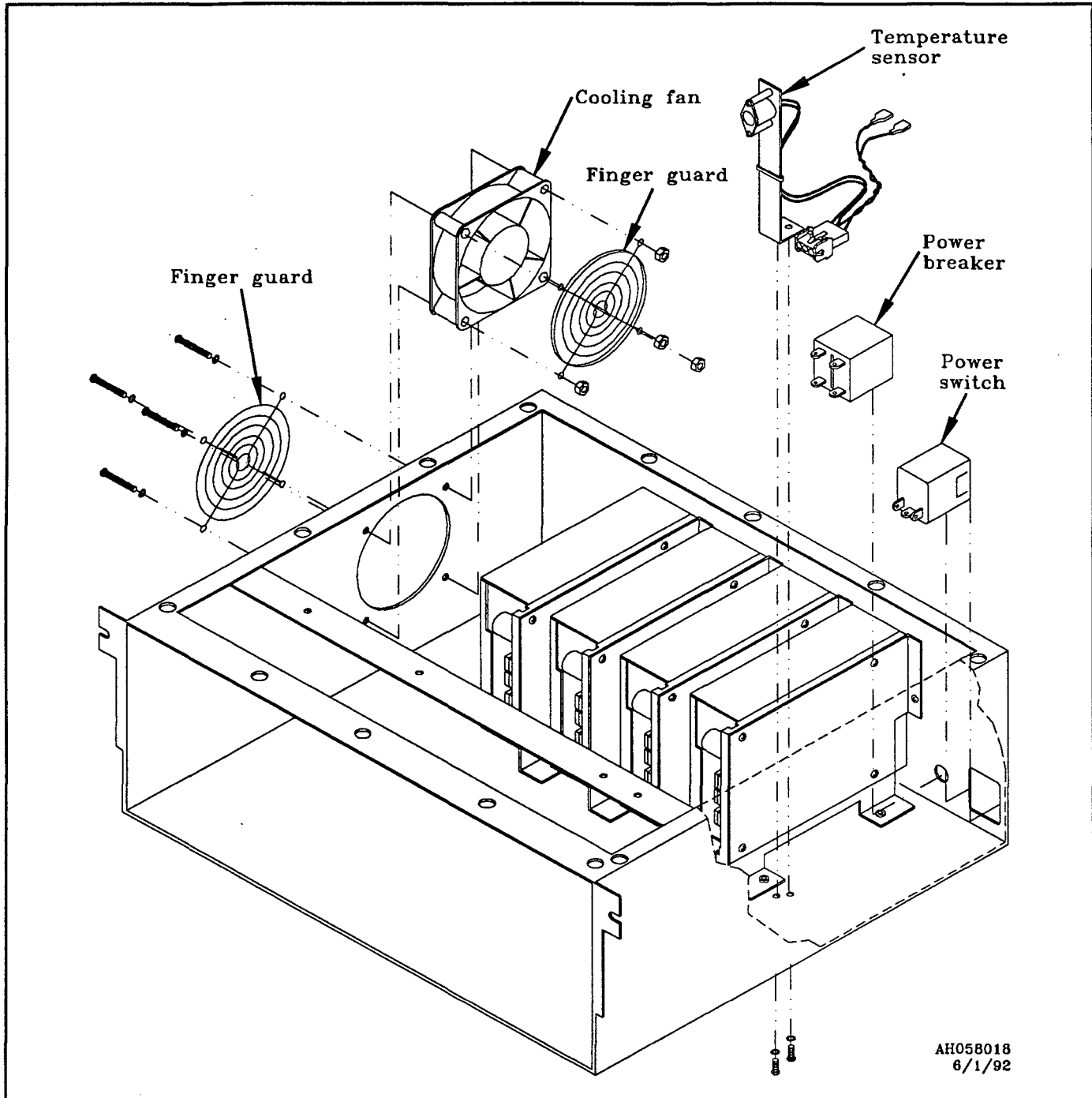

4.7.1 Removal

1. Do the preservice procedures listed in Section 4.3 on page 4-5.

Caution

Fan nuts are not captive and may be lost within the chassis. This may cause damage to equipment.

2. Remove the 4 screws and 4 nuts attaching the fan to the side of the DAT chassis.
3. Disconnect the fan power cable.
4. Remove the fan.

4.7.2 Replacement

1. Connect the power cable to the fan.
2. Position the fan to the side of the DAT chassis.
3. Install the 4 screws and 4 nuts that attach the fan to the DAT chassis.
4. Do the postservice procedures listed in Section 4.11 on page 4-21.

4.8 DAT chassis power breaker

This section gives the procedures for removing and replacing the power breaker from the back of the DAT chassis. See Figure 4-11.

4.8.1 Removal

1. Do the preservice procedures listed in Section 4.3 on page 4-5.
2. Mark and disconnect the 4 wires connected to the chassis power breaker.
3. Remove the nut holding the breaker to the DAT chassis rear panel.
4. Remove the chassis power breaker.

4.8.2 Replacement

1. Position the chassis power breaker in the hole in the rear panel of the DAT chassis.
2. Install the nut that holds the breaker to the rear panel of the DAT chassis.
3. Connect the 4 wires to the chassis power breaker.
4. Do the postservice procedures listed in Section 4.11 on page 4-21.

4.9 DAT chassis power switch

This section gives the procedures for removing and replacing the DAT chassis power switch. See Figure 4-11.

4.9.1 Removal

1. Do the preservice procedures listed in Section 4.3 on page 4-5.
2. Remove the DAT chassis power breaker.
3. Mark and disconnect the 2 wires connected to the DAT chassis power switch.
4. Push the stop tabs on each side of the power switch inward and slide the power switch out of the rear of the chassis.

4.9.2 Replacement

1. Push the power switch into the rear of the DAT chassis until the stop tabs lock into place.
2. Connect the 2 wires to the DAT chassis power switch.
3. Install the DAT chassis power breaker.
4. Do the postservice procedures listed in Section 4.11 on page 4-21.

4.10 DAT chassis temperature sensor

This section gives the procedures to remove and replace the DAT chassis temperature sensor. See Figure 4-11.

4.10.1 Removal

1. Do the preservice procedures listed in Section 4.3 on page 4-5.
2. Mark and disconnect the 2 wires connected to the DAT chassis power breaker.
3. Uncouple the temperature sensor cable from the wiring harness.
4. Remove the 2 screws that hold the temperature sensor to the bottom of the DAT chassis.

4.10.2 Replacement

1. Position the temperature sensor on the bottom of the DAT chassis.
2. Install the 2 screws that hold the temperature sensor to the bottom of the DAT chassis.
3. Couple the wiring harness to the temperature sensor coupler. ↗
4. Connect the 2 wires to the DAT chassis power breaker.
5. Do the postservice procedures listed in Section 4.11 on page 4-21.

4.11 Postservice procedures

This section gives procedures that need to be performed after any of the removal and replacement procedures are done:

1. Position the top panel on the chassis and lock the 14 captive screws in place.
2. Connect the SCSI input cable and the power cable to the rear of the DAT chassis.
3. On the back of the DAT chassis, set the chassis power switch to the ON position. See Figure 4-5 on page 4-8 or Figure 4-6 on page 4-9.
4. Push the buttons inward on the side rails and slide the DAT chassis into the expansion cabinet.
5. Install the 2 screws that hold the DAT chassis in the expansion cabinet.
6. Position the front panel on the chassis and secure the 2 captive screws.
7. Return the expansion cabinet stabilizer bars to their retracted position.
8. Set the VMEbus chassis power control switch to the ON position.
9. Return power to the expansion cabinet.
 - To return power to a CONVEX EXP-101 or EXP-102 expansion cabinet, connect the power cord to the power source.
 - To return power to a CONVEX EXP-105 high-performance expansion cabinet, set the main power control switch to the ON position.

4.12 DAT chassis and DAT drive IPB

This section supplies an Illustrated Parts Breakdown (IPB) for the DAT chassis, drive, power supply, and all associated cables.

Tables 4-2 and 4-3 and Figures 4-12 and 4-13 list and illustrate the tape unit and power supply field replacement units (FRUs).

Table 4-2

Vertical-mount tape drive and power supply parts list

Figure No.	Item number	CONVEX part number	Description
4-11	(See footnote 1)	500-000274-200	DAT manual-load tape drive subassembly (without compression)
4-11	1	207-000017-200	DAT manual-load tape drive (without compression)
4-11	2	320-001646-500	Tape drive bracket, vertical-mount
4-11	3	310-005200-001	Tape drive bracket screw 3 mm x 6 mm (bracket to drive)
	(See footnote 2)	500-000304-200	Power supply subassembly with bracket attached
4-11	4	200-001016-200	Power supply
4-11	5	320-001648-500	Power supply bracket
4-11	6	310-002301-002	Power supply bracket screw (bracket to power supply) 6-32 in. x 1/4 in.
4-11	7	310-002302-004	Power supply bracket screw (chassis to bracket) 6-32 in. x 3/8 in. with washer

¹Consists of items 1-7.

²Consists of items 4-7.

Table 4-3

Horizontal-mount drive parts list

Figure No.	Item number	CONVEX part number	Description
4-12	(See footnote 1)	500-000529-200	DAT manual-load tape drive subassembly (with compression)
NA	(See footnote 1)	500-000530-200	DAT AutoLoader tape drive assembly
4-12	1	207-000019-200	DAT AutoLoader tape drive
4-12	2	207-000021-200	DAT manual-load tape drive (with compression)
4-12	3	320-002483-500	Tape drive bracket, horizontal-mount
4-12	4	310-005200-001	Tape drive bracket screw 3 mm x 6 mm (bracket to drive)
4-12	5	310-200301-001	Washer #6
4-12	6	310-002301-002	Tape drive bracket screw (chassis to bracket) 6-32 in. x 3/8 in.

¹Consists of items 2, 4, 5, and items 4-7 listed in Table 4-11.

²Consists of items 1-4 and items 4-7 listed in Table 4-11.

Figure 4-12
DAT vertical-mount drive and power supply IPB

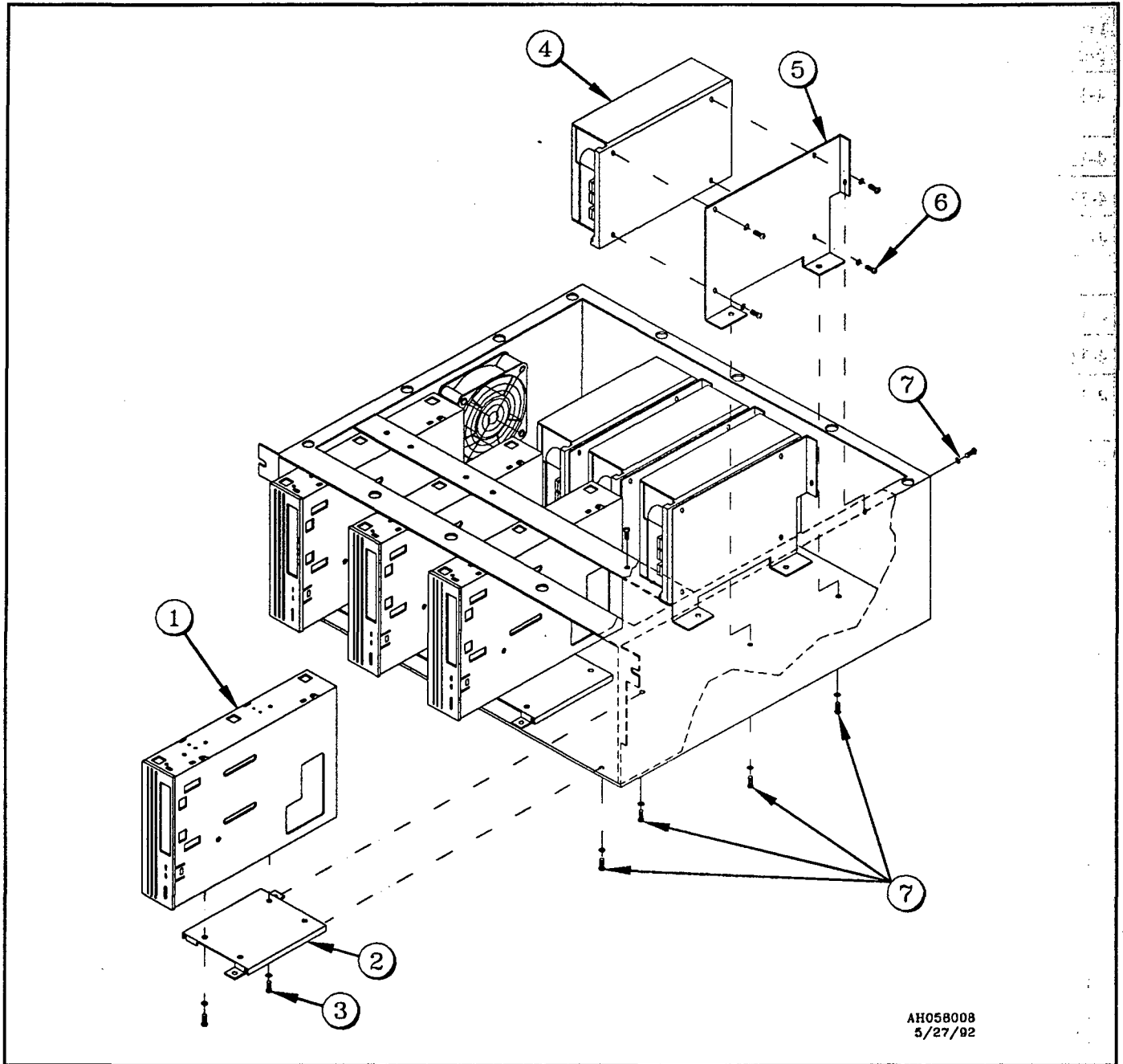

Figure 4-13
DAT horizontal-mount drive IPB

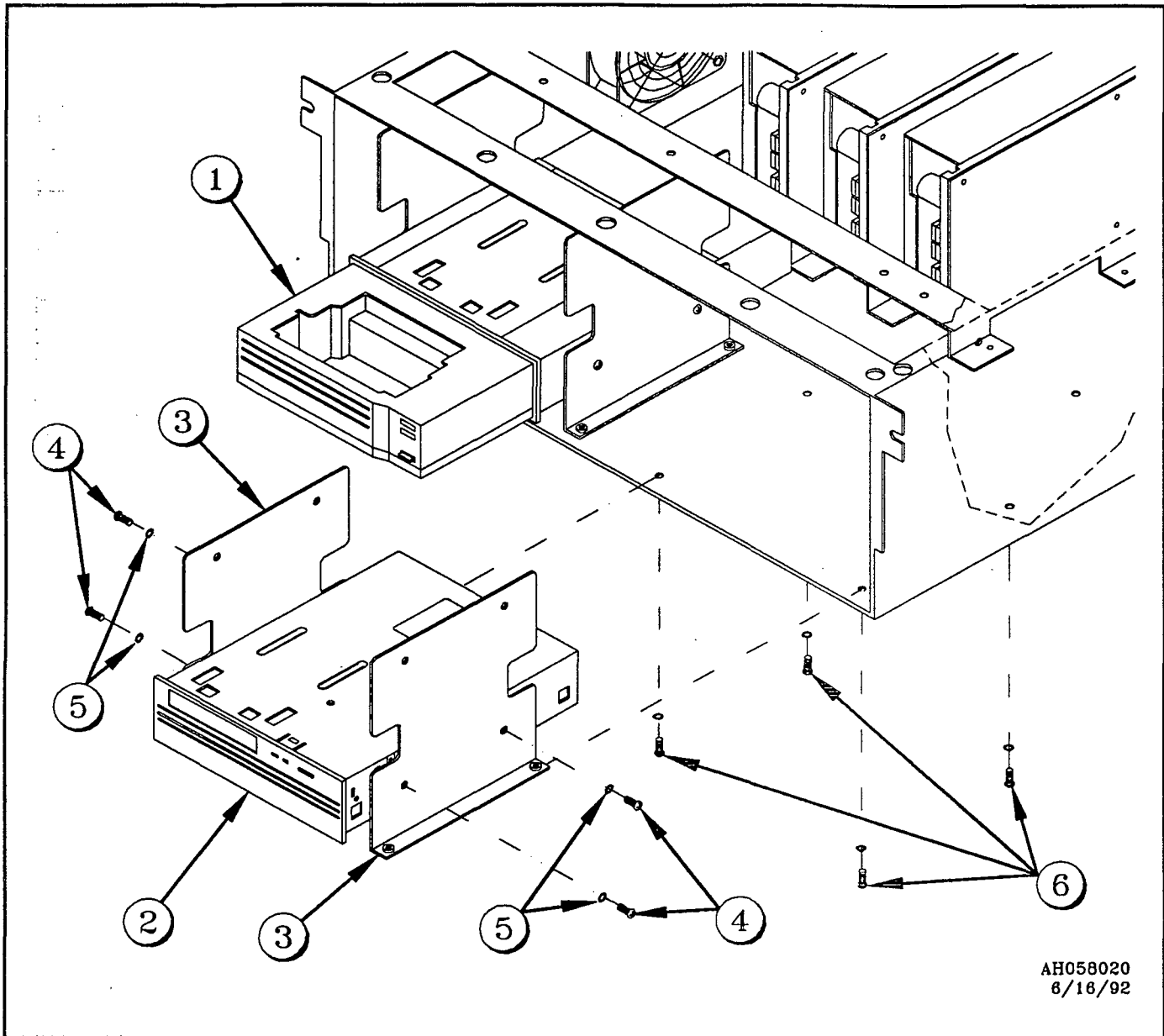

Table 4-4 and Figure 4-14 list and illustrate the hardware related to the DAT drive and chassis.

Table 4-4
Fan, sensor, breaker, and switch list

Item number	CONVEX part number	Description
(See footnote 1)	500-000309-200	Fan subassembly
1	310-002301-001	Fan assembly screws 6-32 in. x $\frac{3}{8}$ in.
2	230-000013-002	Cooling fan finger guard
3	230-000013-001	Cooling fan
(See footnote 2)	500-000310-200	Thermostat subassembly (recommended FRU)
4	310-000200-003	Thermostat screw 4-40 in. x $\frac{1}{4}$ in.
5	250-000013-002	Thermostat
6	253-000113-003	Circuit breaker
7	125-000011-001	DAT chassis power switch
8	310-002302-004	Thermostat bracket screw 6-32 in. x $\frac{3}{8}$ in.

¹Consists of items 1, 2, and 3.

²Consists of items 4 and 5.

Figure 4-14
Fan, sensor, breaker, and switch IPB

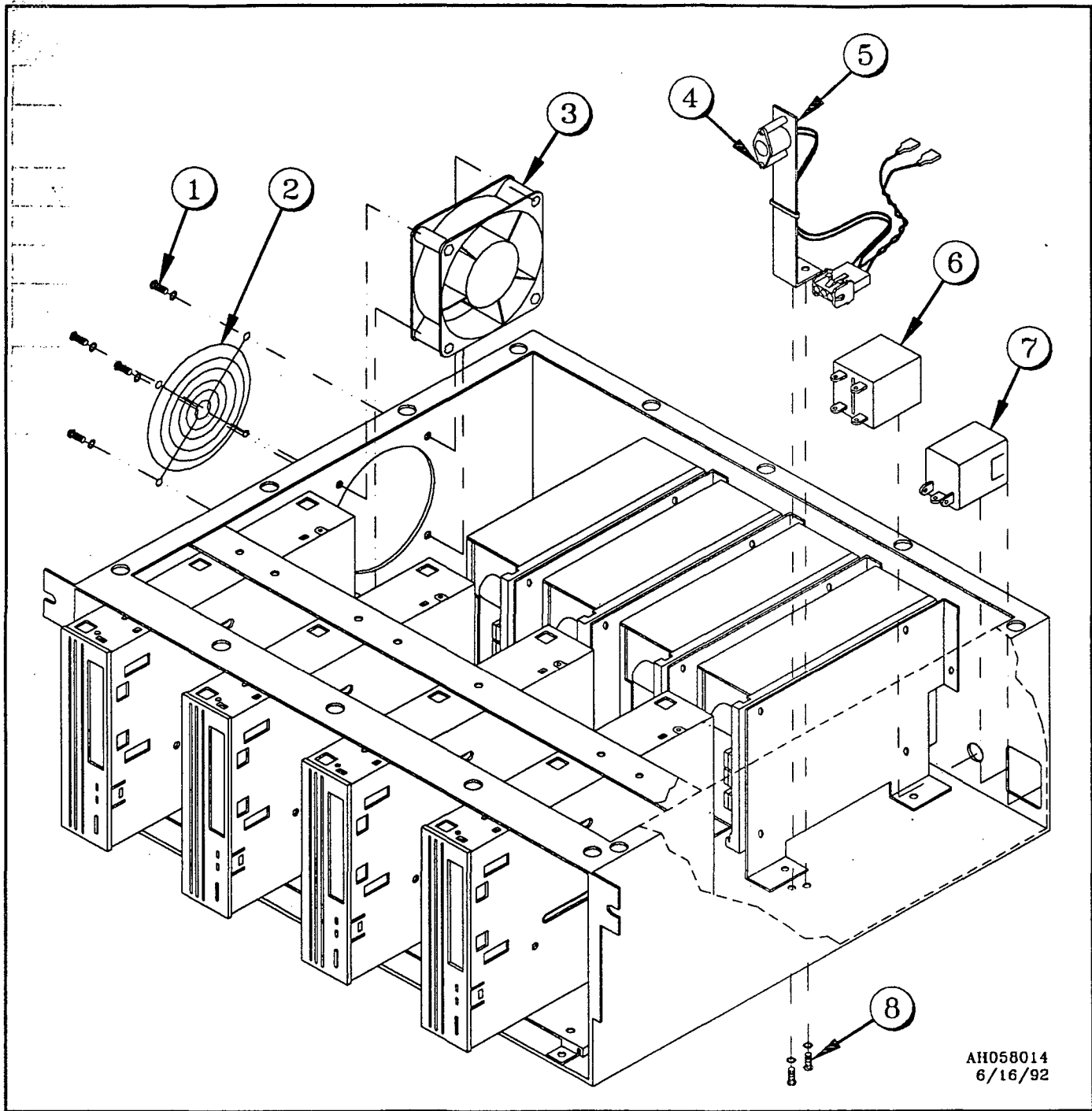

Table 4-5 and Figures 4-15 through 4-17 list and illustrate the cables related to the DAT drive and SCSI host adapter.

Table 4-5
DAT drive and power cabling
list

Item number	CONVEX part number	Description
1	603-020050-200	Fan power cable assembly
2	603-060029-200	DAT drive power daisy-chain cable assembly
3	603-020049-200	Power supply daisy-chain cable assembly
4	603-020001-200	Filter and chassis switch cable assembly
5	603-010029-200	Ground strap cable assembly
6	601-500045-201	Internal SCSI DAT drive daisy-chain cable assembly, vertical-mount
7	601-500049-200	Internal SCSI differential DAT drive daisy-chain cable assembly, horizontal-mount

Figure 4-15
DAT vertical-mount drive and power cabling IPB

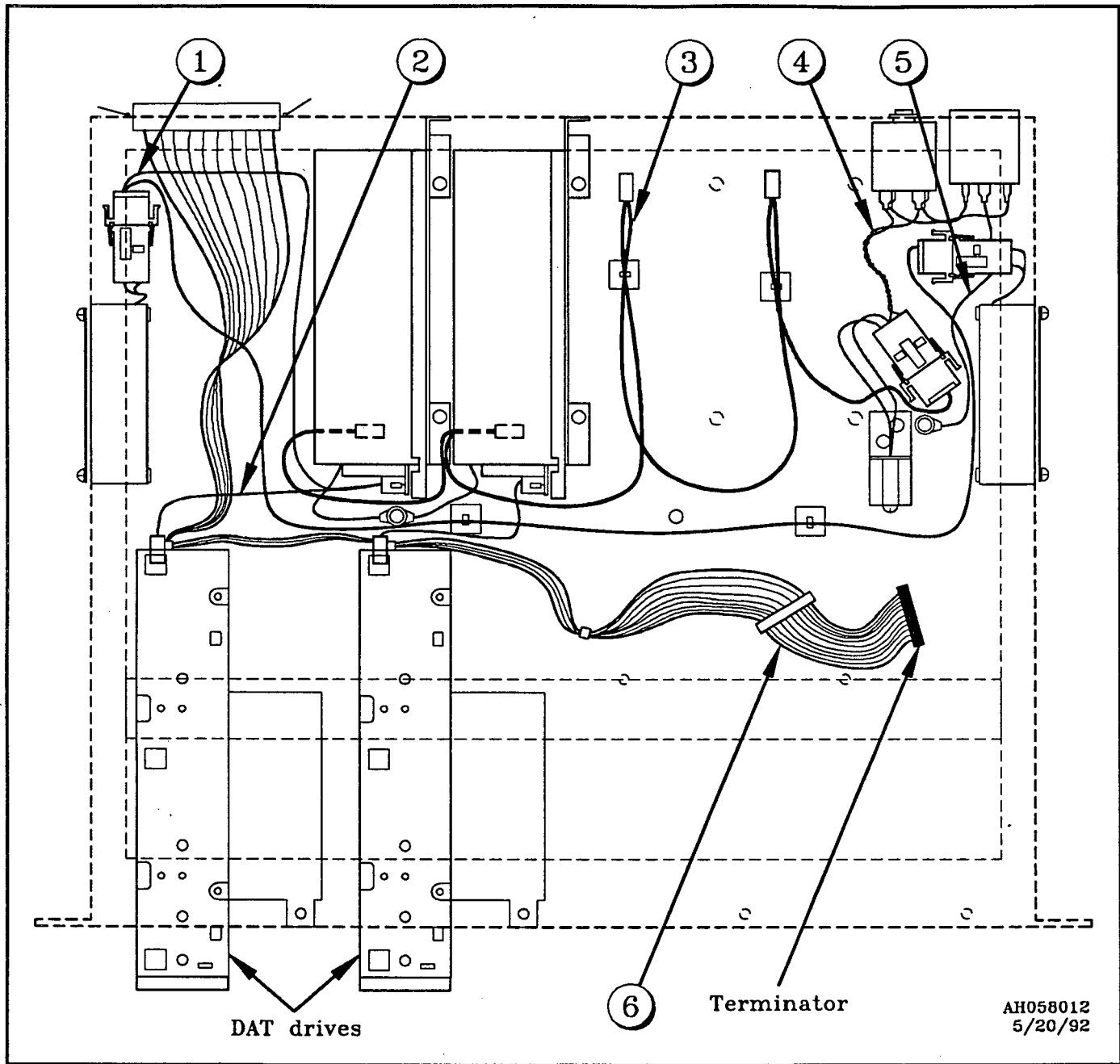

Figure 4-16
DAT horizontal-mount drive and power cabling IPB

10-10-10
EAC

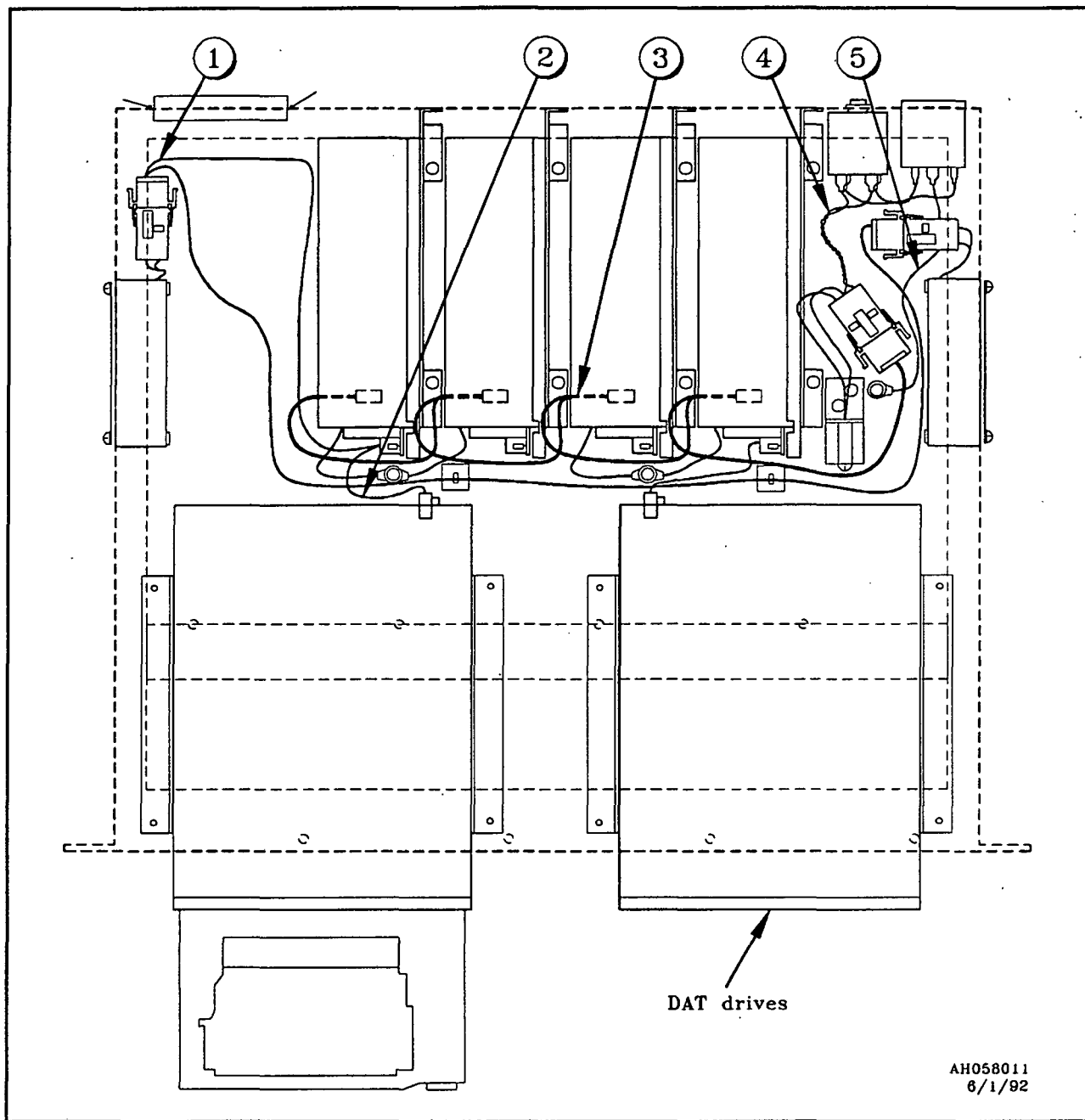
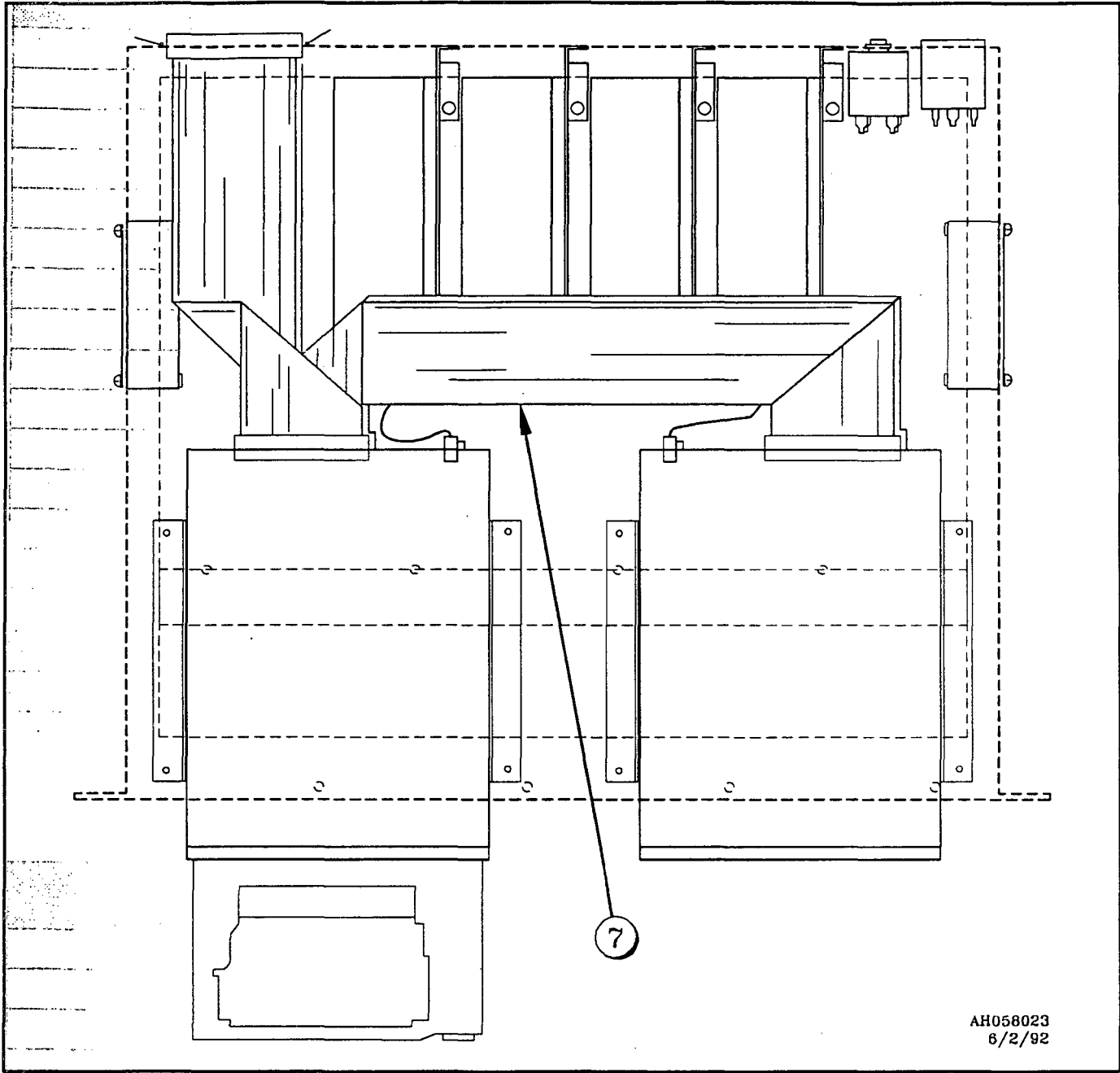

Figure 4-17
DAT horizontal-mount internal SCSI cabling IPB



AH058023
6/2/92

Table 4-6 and Table 4-7 list other FRUs associated with the DAT drive.

Table 4-6
Miscellaneous mechanical
parts list

CONVEX part number	Description
500-003843-22	DAT chassis subassembly ¹
320-001642-500	DAT chassis (vertical mount)
312-001642-500	DAT chassis (horizontal mount)
312-000345-001	DAT chassis slide rail (universal)
320-002370-500	DAT chassis front panel, vertical-mount
320-002489-500	DAT chassis front panel, horizontal-mount
320-002371-500	DAT chassis front panel blank insert
320-001146-500	DAT chassis end bracket
320-001644-500	DAT chassis cover
320-002479-500	DAT chassis back panel
310-002302-004	Back panel screws 6-32 x 3/8 with washer
320-001461-500	Front panel mounting bracket, vertical-mount
320-002485-500	Front panel mounting bracket, horizontal-mount
312-000346-001	Front panel mounting bracket Monel mesh
310-002501-001	Front panel mounting bracket screws 10-32 x 1/2
310-150503-001	RETMA rail nut
310-002501-003	RETMA rail screw 10-32 x 1/2

¹Consists of all parts listed in this table, plus all items in Table 4-4 and items 1 and 4-6 in Table 4-5.

Table 4-7
Miscellaneous parts list

CONVEX part number	Description
207-000017-001	DAT cleaning cassette
621-000105-001	DAT cassette, 1.3 Gbyte, 60 meter, blank
621-000105-002	DAT cassette, 2.0 Gbyte, 90 meter, blank
207-000019-001	DAT magazine, 5-cartridge
207-000015-011	Differential SCSI terminator

Index

I

/ioconfig entries 3-1
/ioconfig file 3-1

A

AC filter cable
 illustration 4-28 - 4-30
AC filter cable part number
 table 4-27
Address
 SCSI, dip switch settings, table 2-14
 SCSI, drive 4-11, 4-15
Areal density 1-1

B

Breaker part number
 chassis power, table 4-25
Breaker, chassis power
 illustration 4-18, 4-26
 removal 4-19
 replacement 4-19

C

Cable
 AC filter part number, table 4-27
 AC filter, illustration 4-28 - 4-30
 chassis switch part number, table 4-27
 chassis switch, illustration 4-28 - 4-30
 drive DC power cable part number, table 4-27
 drive DC power, illustration 4-28 - 4-30
 Fan DC power, illustration 4-28 - 4-30
 Fan DC power, part number, table 4-27
 ground strap part number, table 4-27
 ground strap, illustration 4-28 - 4-30
 internal SCSI, horizontal-mount chassis 2-12
 internal SCSI, version 1 2-12
 internal SCSI, version 2 2-12
 power supply cable part number, table 4-27
 power supply, illustration 4-28 - 4-30
 SCSI DAT drive part number, table 4-27
 SCSI DAT drive, illustration 4-28, 4-30
Cable length
 DAT chassis 2-3
 SCSI host adapter 2-3
Cassette
 cleaning drive 4-4
 cleaning, life of 4-4
 initializing blank in AutoLoader magazine 2-20
 manual removal 4-4
Chassis
 installing 2-7
 SCSI cable length 2-3
 SCSI connection 1-3
Chassis cooling fan
 finger guard, illustration 4-18
 illustration 4-18, 4-26
 removal 4-19

 Replacement 4-19
Chassis cooling fan finger guard
 illustration 4-26
 part number, table 4-25
Chassis cooling fan part number
 table 4-25
Chassis front panel blank insert part number
 table 4-31
Chassis front panel part number
 table 4-31
Chassis power breaker
 illustration 4-18, 4-26
 removal 4-19
 replacement 4-19
Chassis power breaker,
 part number, table 4-25
Chassis power switch
 illustration 4-18, 4-26
 part number, table 4-25
 removal 4-20
 replacement 4-20
Chassis slide rail part number
 table 4-31
Chassis switch cable
 illustration 4-28 - 4-30
Chassis switch cable part number
 table 4-27
Chassis temperature sensor
 illustration 4-18, 4-26
 part number, table 4-25
 removal 4-20
 replacement 4-20
Chassis, vertical-mount
 power switch, illustration 4-8
 SCSI connection, illustration 4-8
Checklist
 unpacking 2-2
Claims
 damage 2-2
Cleaning cassette
 life of 4-4
Cleaning drive
 cleaning cassettes 4-4
 description of 4-4
 LEDs 4-4
 contact utility 0-xiv
CONVEX EXP-101 expansion cabinet
 power 2-5, 4-6
CONVEX EXP-102 expansion cabinet
 power 4-6
CONVEX EXP-102 expansion cabinet
 power 2-5
CONVEX EXP-105 expansion cabinet
 power 2-5, 4-6
 power controller, illustration 2-5
ConvexOS
 software integration 3-1
 versions required for functionality 3-1
Cooling fan finger guard
 chassis, illustration 4-18, 4-26
Cooling fan finger guard part number
 chassis, table 4-25
Cooling fan part number
 chassis, table 4-25
Cooling fan, chassis

replacement 4-19
Cooling fan, chassis,
illustration 4-18, 4-26
removal 4-19
customer support
telephone numbers for 0-xii

D

Damage
inspection for 2-2
Damage claims 2-2
Data rate 1-1
DDS recording format 1-1
dev_vscsit diagnostic 3-3
device codes, /ioconfig file
DAT drive system (vertical mount) 3-1
SCSI host adapter 3-1
Diagnostic
dev_vscsit 3-3
Digital Data Storage
see DDS
Dip switch settings
SCSI address, table 2-14
table 2-14
Drive
illustration 4-23
specifications 1-4
testing 3-3
vertical-mount, chassis position illustrated 2-16
Drive bracket
illustration 4-23
vertical-mount illustrated 2-16
Drive bracket, horizontal-mount
illustration 4-14
Drive bracket, vertical mount
illustration 4-10
Drive DC power cable
illustration 4-28 - 4-30
Drive DC power cable part number
table 4-27
Drive power supply
illustration 2-11, 4-17
removal 4-16
replacement 4-16
Drive terminators
illustration 4-12
Drive unit
removal 4-11
replacement 4-11
selecting SCSI address 4-11, 4-15
Drive unit, horizontal-mount
illustration 4-14
Drive unit, vertical-mount
illustration 4-10
Drive, cleaning
description of 4-4

E

Electrostatic Discharge
see ESD
ESD damage
prevention 2-1
Expansion cabinet
CONVEX EXP-105 power 4-6
power removal 4-6

Expansion cabinet power 2-5
Expansion cabinet stabilizer bars 2-6, 4-6
illustration 4-7

F

Fan DC power cable
illustration 4-28 - 4-30
Fan DC power cable part number
table 4-27
Finger guard
chassis cooling fan, illustration 4-18, 4-26
Finger guard part number
chassis cooling fan, table 4-25
Front Panel LEDs 4-1
description, table 4-3
Front panel LEDs, AutoLoader
location, illustration 4-3
Front panel LEDs, manual-load
location, illustration 4-2
Front panel mounting bracket
grounding pads 2-8
Front panel mounting bracket part number
table of 4-31
Front panel power switch
illustration 2-3

G

Ground strap cable
illustration 4-28 - 4-30
Ground strap cable part number
table 4-27
Grounding pads
front panel mounting bracket 2-8
Grounding pads part number
table 4-31

H

Helical scan recording 1-1
Horizontal-mount drive
illustration 4-24
Horizontal-mount drive bracket
illustration 4-24

I

Inspection and unpacking 2-1
Inspection for damage 2-2
Installation
see also Preinstallation
magazine 2-20
overview 2-1
Installing DAT chassis 2-7

L

LEDs
cleaning drive, description 4-4
description, table 4-3
front panel 4-1
LEDs, AutoLoader

location, illustration 4-3
LEDs, manual-load
location, illustration 4-2

M

Magazine
initializing blank cassette 2-20
installation 2-20
unloading 2-20
Maintenance
Preventive 4-1
MTC-202
SCSI host adapter 3-1

O

overview
maintenance procedures and IPB 4-1
planning procedures 1-1
software integration and test 3-1
Specifications 1-1
unpacking and installation 2-1

P

Packing
save for return shipping 2-2
Part number
AC filter cable, table 4-27
chassis cooling fan finger guard, table 4-25
chassis cooling fan, table 4-25
chassis front panel blank insert, table 4-31
chassis front panel, table 4-31
chassis power breaker, table 4-25
chassis power switch, table 4-25
chassis slide rail, table 4-31
chassis switch cable, table 4-27
chassis temperature sensor, table 4-25
drive DC power cable, table 4-27
fan DC power cable, table 4-27
front panel mounting bracket, table 4-31
ground strap cable, table 4-27
grounding pads, table 4-31
power supply cable, table 4-27
SCSI DAT drive cable, table 4-27
Post-service procedures 4-21
Power
CONVEX EXP-101 expansion cabinet 2-5
CONVEX EXP-102 expansion cabinet 2-5
CONVEX EXP-105 expansion cabinet 2-5
expansion cabinet 2-5
Power breaker part number
chassis, table 4-25
Power breaker, chassis,
illustration 4-18, 4-26
removal 4-19
replacement 4-19
Power controller
CONVEX EXP-105 expansion cabinet 2-5
Power down
system 2-3
Power supply bracket
illustration 4-23
Power supply cable
illustration 4-28 - 4-30
Power supply cable part number
table 4-27

Power supply, drive
illustration 2-11
Power supply, drive,
illustration 4-17, 4-23
removal 4-16
replacement 4-16
Power switch
front panel, illustration 2-3
vertical-mount chassis, illustration 4-8
VMEbus chassis 2-4
VMEbus chassis, illustration 4-5
Power switch part number
chassis, table 4-25
Power switch, chassis,
illustration 4-18, 4-26
removal 4-20
replacement 4-20
Preinstallation 2-3
Preventive maintenance 4-1

R

Recording density 1-1
Recording format
ANSI Digital Data Storage 1-1
Return shipping
save packing for 2-2

S

SCSI address
dip switch settings, table 2-14
drive 4-11, 4-15
SCSI cable, internal
horizontal-mount chassis 2-12
version 1 2-12
version 2 2-12
SCSI connection
chassis 1-3
vertical-mount chassis 4-8
SCSI DAT drive cable
illustration 4-28, 4-30
SCSI DAT drive daisy-chain cable part number
table 4-27
SCSI host adapter
max cable length 2-3
MTC-202 Vioconfig entry 3-1
Sensor
chassis temperature, removal 4-20
chassis temperature, replacement 4-20
Shipping
save packing for return 2-2
Software integration
ConvexOS 3-1
Specifications
DAT drive 1-4
Stabilizer bars
expansion cabinet 4-6
expansion cabinet, illustration 2-6, 4-7
Switch
chassis power, illustration 4-18, 4-26
chassis power, removal 4-20
chassis power, replacement 4-20
front panel power, illustration 2-3
VMEbus chassis power 2-4
VMEbus chassis power, illustration 4-5
Switch part number
chassis power, table 4-25
System power down 2-3

T

- Technical Assistance Center (TAC)
 - submitting trouble reports 0-xiii
 - telephone numbers for 0-xiv
- telephone numbers
 - technical assistance 0-xiii
- Temperature sensor part number
 - chassis, table 4-25
- Temperature sensor, chassis,
 - illustration 4-18, 4-26
 - removal 4-20
 - replacement 4-20
- Terminators
 - drive, illustration 4-12
 - internal SCSI cable, version 1 2-12
 - internal SCSI cable, version 2 2-12
- Testing
 - dev_vscsit diagnostic 3-3
 - Drive 3-3
- trouble reports
 - how to submit 0-xiv

U

- Unpacking
 - checklist 2-2
 - overview 2-1
- Unpacking and inspection 2-1

V

- VMEbus chassis
 - power removal 4-5
 - power switch, illustration 4-5
- VMEbus chassis power switch 2-4